

- 1) Clean axle tubes for welding.
- 2) Set axle at proper pinion angle.
- 3) Bolt joint into lower control arm mounts.
- 4) Locate lower control arm mount on axle.
- 5) Weld outside of both mounts.
- 6) Locate spring perches.
- 7) Weld around axle tube.
- 8) Locate spring bucket plate.
- 9) Make three 1" welds around plate.
- 10) Locate lower shock mounts.
- 11) Weld three sides to axle tube.
- 12) Locate truss on axle.
- 13) Weld four sides, both ends to axle tubes.

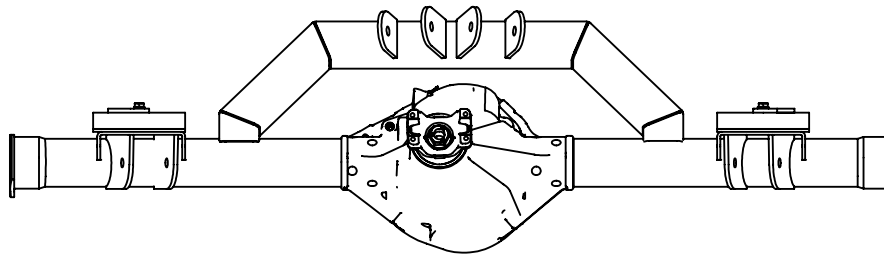
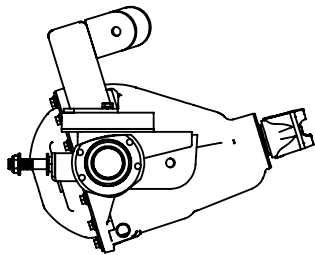
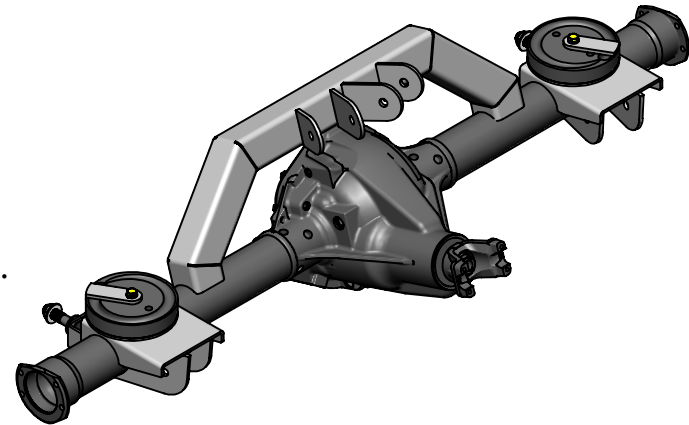
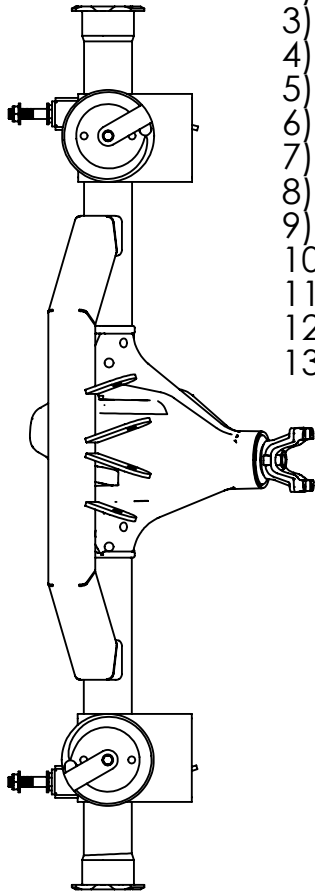

TITLE:

XJ Rear Coil Conversion Axle
Bracket Kit (3.00" Tube)

SIZE	DWG. NO.	REV
A	1201130	A

SCALE: 1:12	WEIGHT:	SHEET 1 OF 4
-------------	---------	--------------

Truss parallel with differential cover

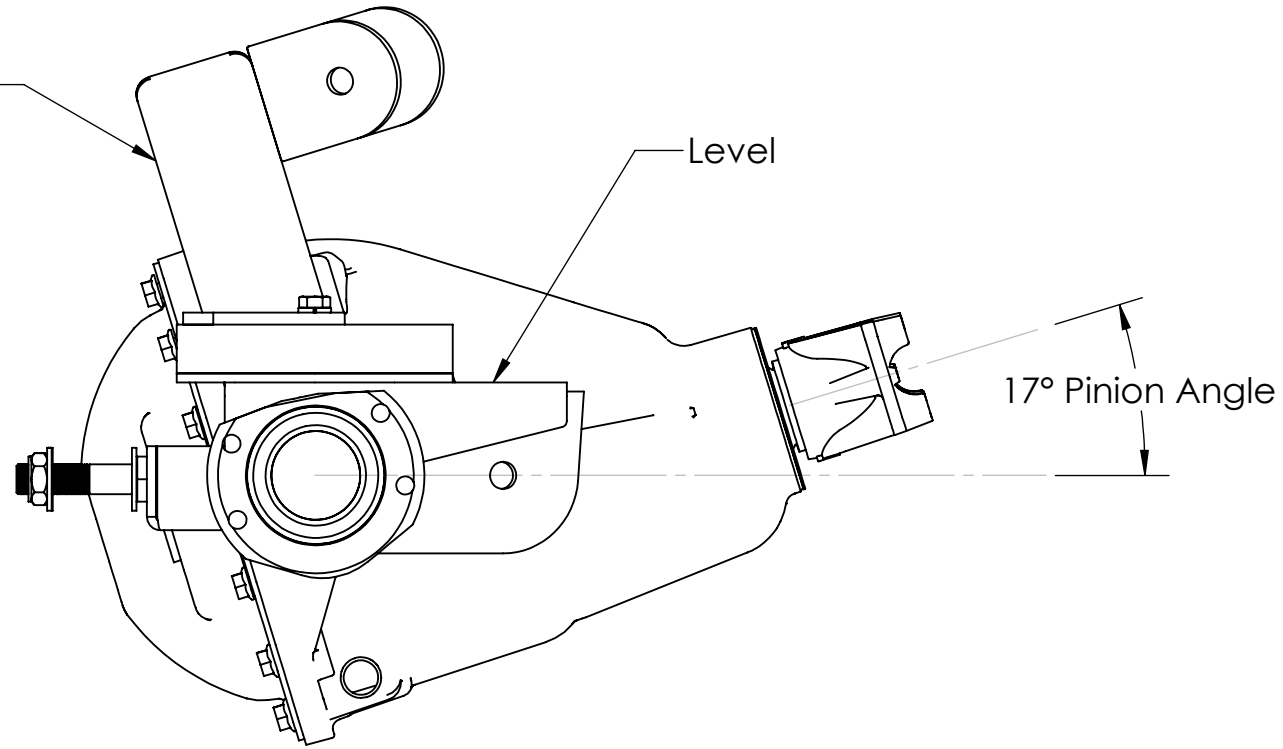

Level

17° Pinion Angle

TITLE:

XJ Rear Coil Conversion Axle
Bracket Kit (3.00" Tube)

SIZE
A

DWG. NO.
1201130

REV
A

SCALE: 1:4 MTL:

SHEET 2 OF 4

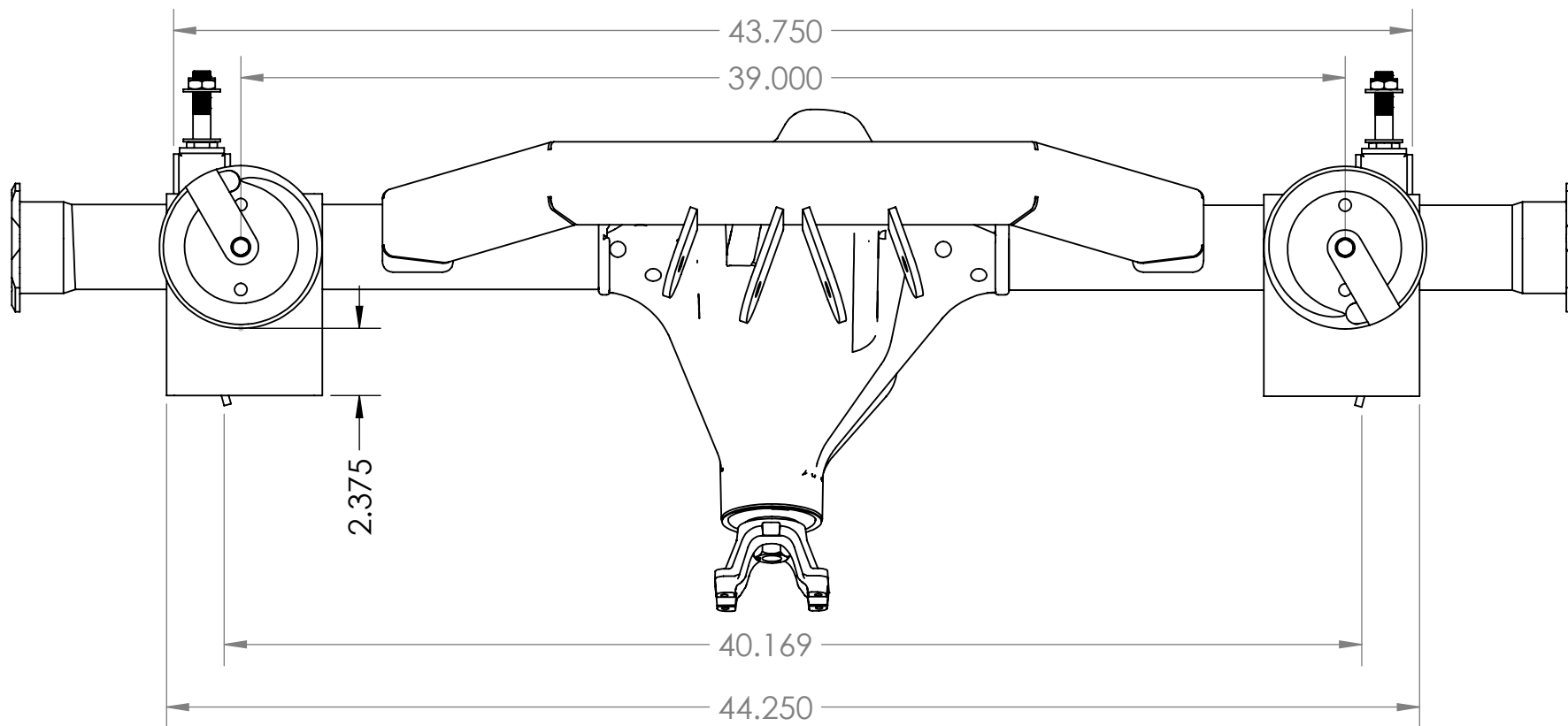

TITLE:		
XJ Rear Coil Conversion Axle Bracket Kit (3.00" Tube)		
SIZE	DWG. NO.	REV
A	1201130	A
SCALE: 1:6	MTL:	SHEET 3 OF 4

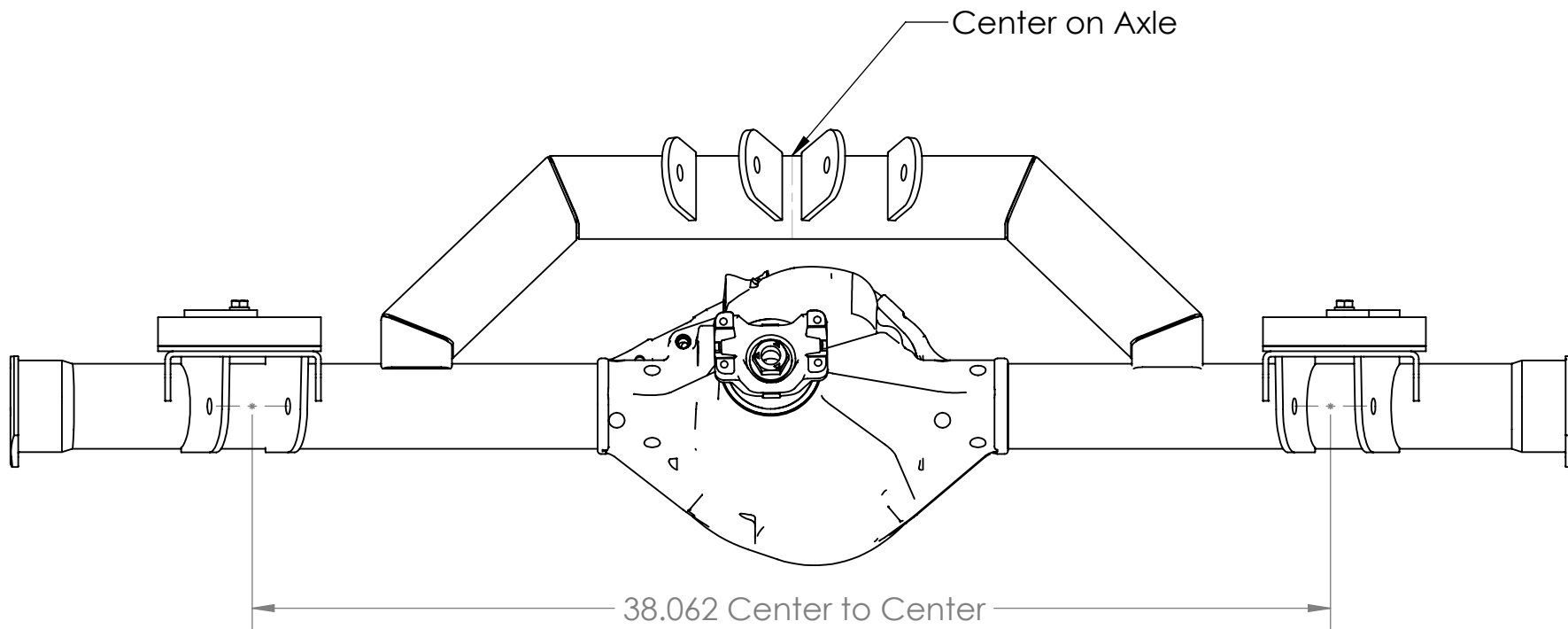

TITLE:

XJ Rear Coil Conversion Axle
Bracket Kit (3.00" Tube)

SIZE
A

DWG. NO.
1201130

REV
A

SCALE: 1:6 MTL:

SHEET 4 OF 4