

CLAYTON OFF ROAD
COR-2909002, COR-2909010
JEEP WRANGLER 2.5", 3.5" RIDE RIGHT + LIFT KIT 2 DR (2018 & UP, JL)

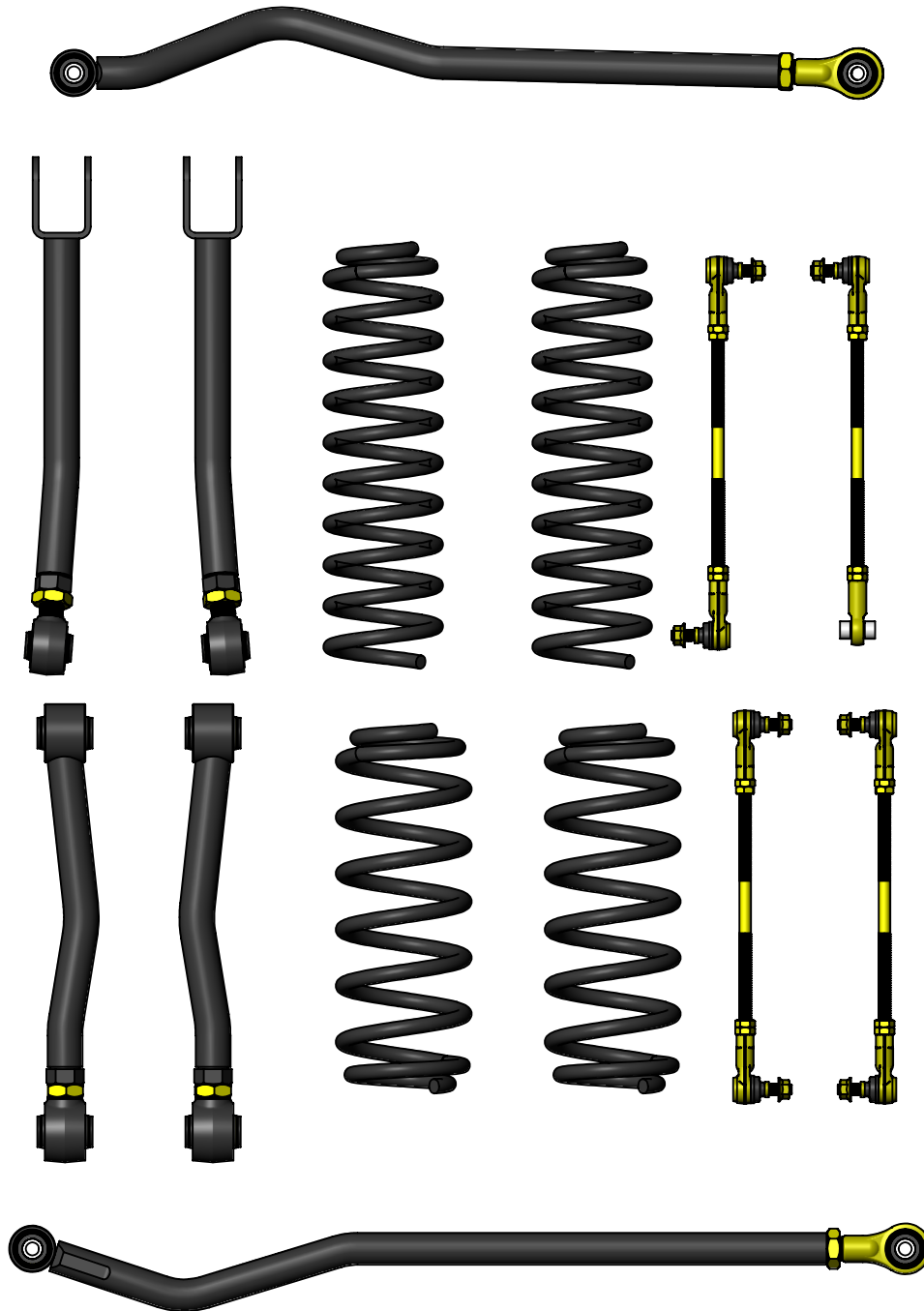

NOTES: This product may require general welding, fabrication and automotive mechanic skills. Welding should only be done by a competent welder. Clayton Off Road implies no guarantees or warranties and is not liable for improper installation. Some grinding and fitment may be required when installing this product. Every vehicle varies slightly and some fabrication may be required. For more information please visit our website.

Recommended starting lengths for track bars and control arms. These lengths can be adjusted as needed for caster angle, drive shaft angles and tire clearance. Please make sure to not exceed the maximum length of the control arms or track bars.

Lift Height >	Stock	2 Door 2.5" Lift	2 Door 3.5" Lift	4 Door 2.5" Lift	4 Door 3.5" Lift
Suspension Component					
Front Upper Control Arms	20.185	19.875	19.688	19.875	19.688
Rear Upper Control Arms	17.425	17.625	17.500		
Front Track Bar	33.779	34.090	34.251	34.090	34.251
Rear Track Bar	37.587	37.860	38.003	37.860	38.003

Refer to individual product part number instructions.

Step 1: Position front of vehicle on jack stands or complete vehicle on lift.

Step 2: Support front axle.

Step 3: Remove front tires.

Step 4: Loosen front track bar bolts.

Step 5: Remove heat shields and loosen upper and lower control arm bolts.

Step 6: Loosen front upper and lower control arm bolts.

Step 7: Remove front sway bar links.

Step 8: Remove front shocks.

Step 9: Remove two brake line clip bolts on both sides.

Step 10: Unclip and disconnect all wires going to the front axle.

Step 11: Lower front axle.

Step 12: Remove front springs.

Step 13: Remove front upper control arm on one side.

Step 14: Install front upper control arm part number COR-1709101 with curve away from the frame.

Step 15: Repeat steps 13 and 14 on other side.

Step 16: Remove front track bar.

Step 17: Install front track bar part number COR-4509100.

Step 18: Install front springs part number COR-1508250 or COR-1508350 depending on lift height

Step 19: Install front shocks.

Step 20: Install front sway bar links part number COR-5109100.

Step 21: Install two brake line clip bolts on both sides.

Step 22: Clip and connect all wires going to the front axle.

Step 23: Install front tires.

Step 24: Position rear of vehicle on jack stands or complete vehicle on lift.

Step 25: Support rear axle.

Step 26: Remove rear tires.

Step 27: Loosen rear track bar bolts.

Step 28: Loosen rear upper and lower control arm bolts.

Step 29: Remove brake line clip bolts on both sides and unbolt parking brake cables.

Step 30: Unclip and disconnect all wires going to the rear axle.

Step 31: Remove rear sway bar links.

Step 32: Remove rear shocks.

Step 33: Lower rear axle.

Step 34: Remove rear springs.

Refer to individual product part number instructions.

Step 35: Remove rear upper control arm on one side.

Step 36: Install rear upper control arm part number COR-1709103.

Step 37: Repeat steps 35 and 36 on other side.

Step 38: Remove rear track bar.

Step 39: Install rear track bar part number COR-4509110.

Step 40: Install rear springs part number COR-1509251 or COR1509351 depending on lift height.

Step 41: Install rear shocks.

Step 42: Install rear sway bar links part number COR-5109110.

Step 43: Install brake line clip bolts on both sides and bolt in parking brake cables.

Step 44: Clip and connect all wires going to the rear axle.

Step 45: Install rear tires.

Step 46: With vehicle sitting at ride height center both front and rear axles under the vehicle by adjusting the front and rear track bars.

Step 47: In the next 2 steps it is very important to set the caster and pinion angle with a jack with the bolts at one end removed then adjust the length of the upper control arms so they are loaded up equally when the jack is removed.

Step 48: Adjust length of front upper arms to have a caster angle of 4.8 degrees. This angle should be within plus or minus 1.00 degrees.

Step 49: Adjust rear pinion angle to keep lower spring perches aligned with upper spring perches. On 2 door models it will be necessary to roll the pinion up to avoid the rear drive shaft from binding on full droop.

Step 50: Tighten all track bar and control arm bolts.

Step 51: Tighten all track bar and control arm jam nuts.

**Clayton Off Road
COR-1709101
Jeep Wrangler Overland + Front Upper Control Arms (2018 & Up, JL)**



NOTES: This product may require general welding, fabrication and automotive mechanic skills. Welding should only be done by a competent welder. Clayton Off Road implies no guarantees or warranties and is not liable for improper installation. Some grinding and fitment may be required when installing this product. Every vehicle varies slightly and some fabrication may be required. For more information please visit our website.

Refer to pictures below.

Step 1: Support axle from rotating, a floor or bottle jack works well.

Step 2: Remove old control arms.

Step 3: Set caster to 4.5 to 5.5 degrees by adjusting the height of the jack.

Step 4: Install arms at frame side, arm should bow away from frame.

Step 5: Adjust control arm to length so that bolts can easily be installed at axle end.

Step 6: Remove jack, and check caster.

Step 7: Torque all bolts to 80 ft-lb.

Step 8: Tighten jam nut using a 1-7/16" wrench

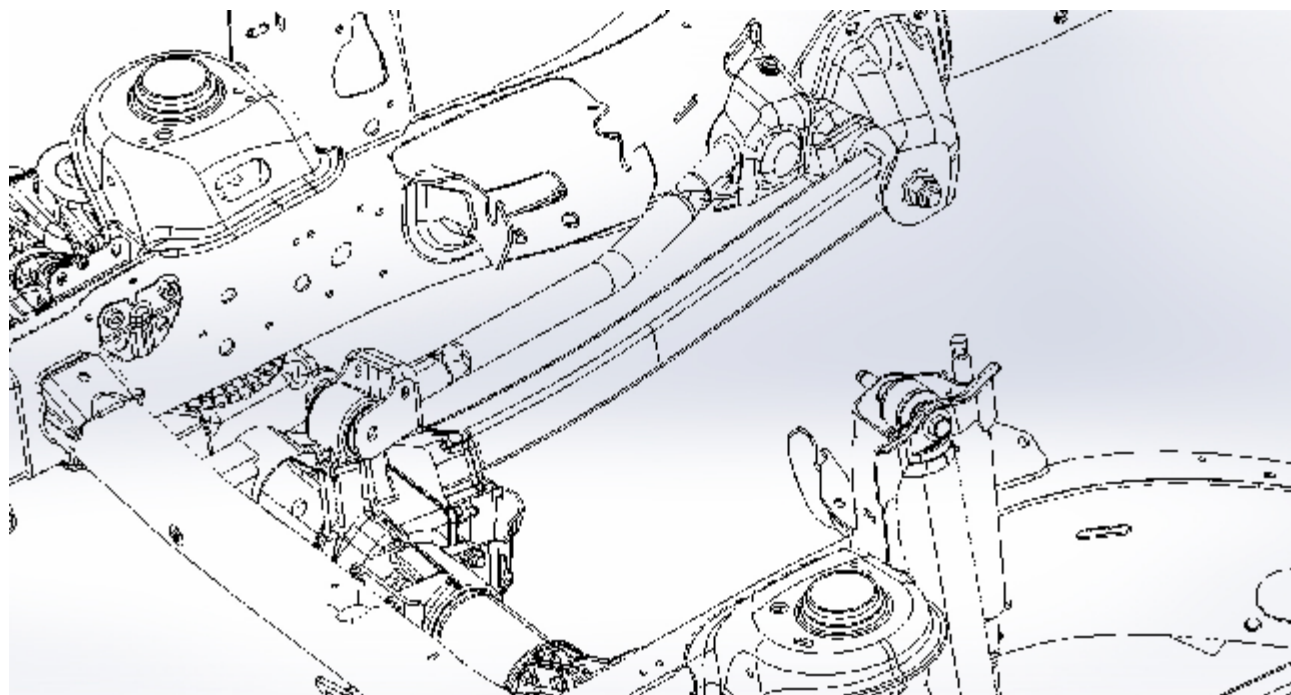
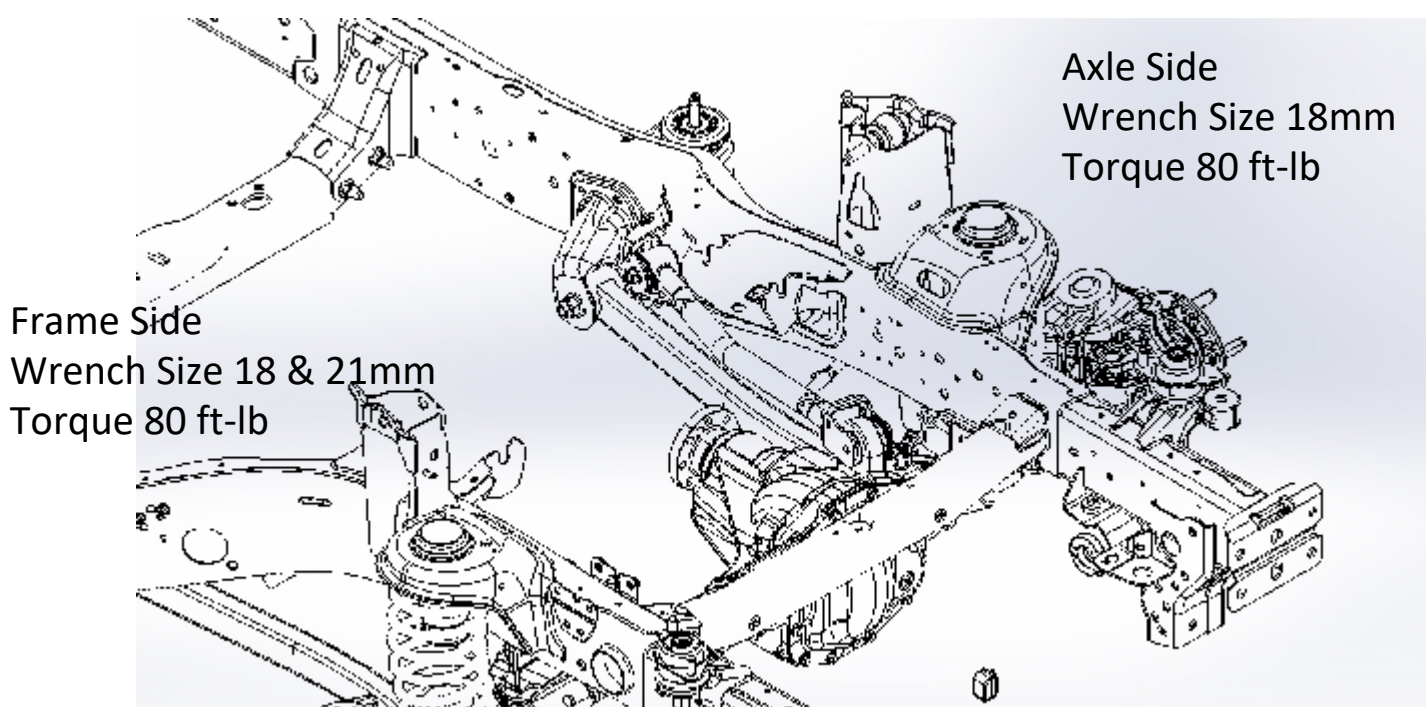

Refer to drawing below for minimum and maximum lengths.

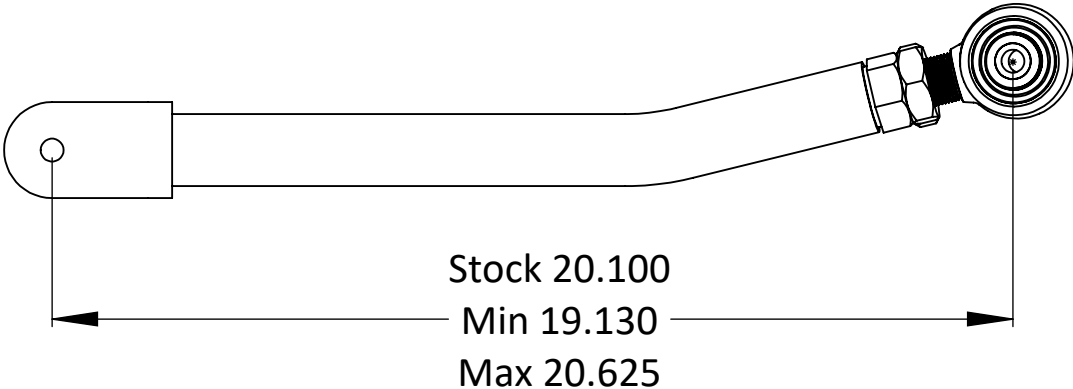

**Clayton Off Road
COR-4509100
Jeep Wrangler Adjustable Front Track Bar (2018 & Up, JL)**

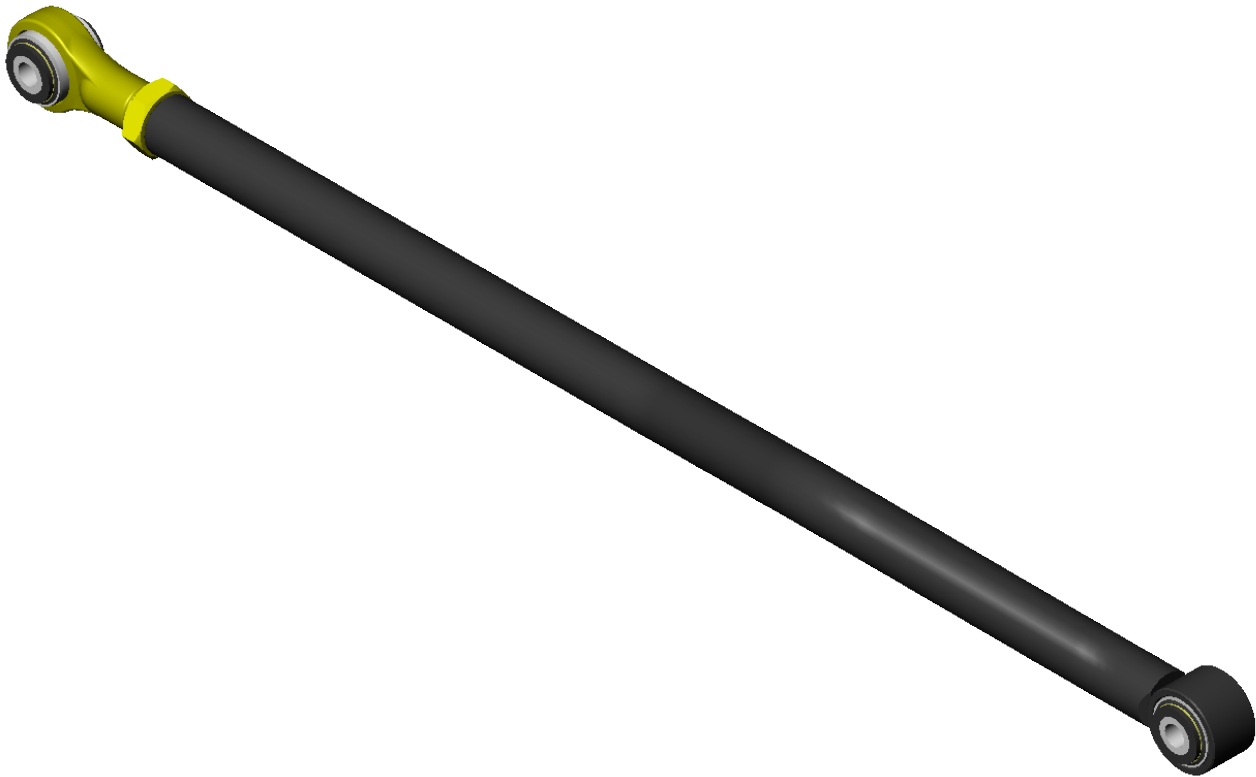

NOTES: This product may require general welding, fabrication and automotive mechanic skills. Welding should only be done by a competent welder. Clayton Off Road implies no guarantees or warranties and is not liable for improper installation. Some grinding and fitment may be required when installing this product. Every vehicle varies slightly and some fabrication may be required. For more information please visit our website.

Refer to pictures below.

Step 1: Remove old track bar.

Step 2: Center frame on axle.

Step 3: Measure length from axle side mount to frame side mount.

Step 4: Adjust track bar to length and run jam nut up to track bar tube.

Step 5: Install new track bar with adjustment end on axle.

Step 6: Install track bar bolts and nuts.

Step 7: Torques both bolts to 110 ft-lb.

Step 8: Tighten jam nut using a 1-7/16" wrench.

Step 9: Make sure Johnny Joint at frame side is centered in bracket.

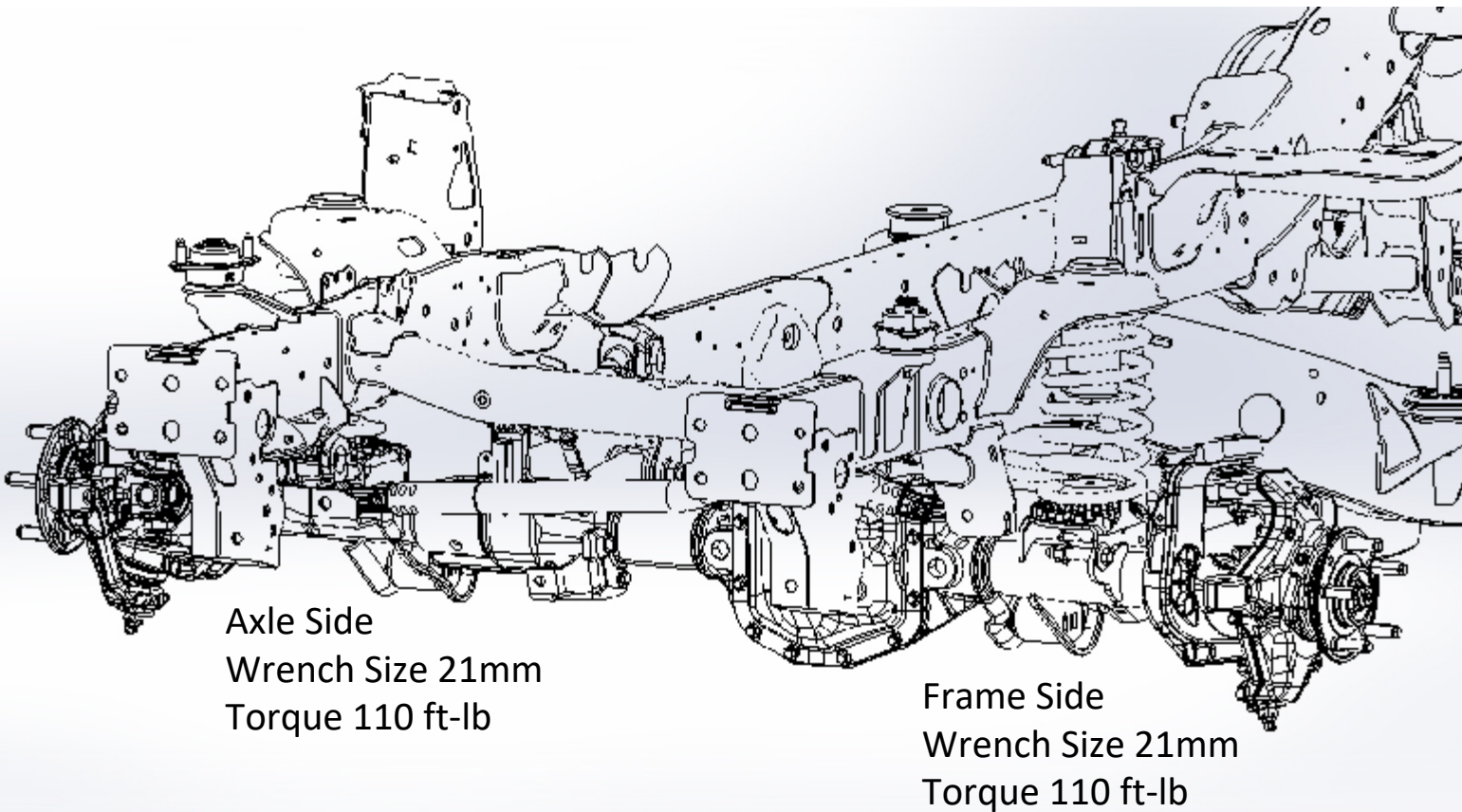

Refer to drawing below for minimum and maximum lengths.

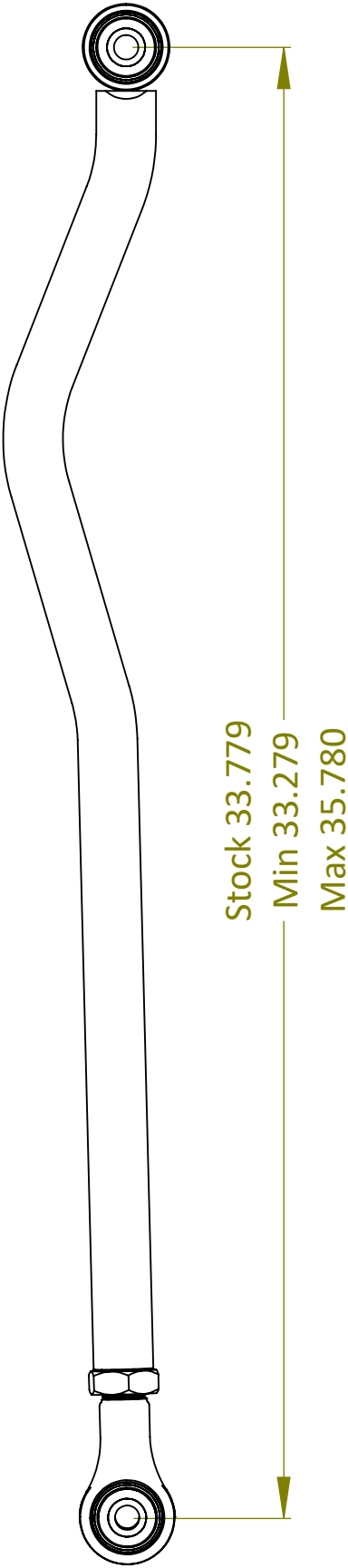

Clayton Off Road
COR-5109100
Jeep Wrangler Adjustable Front Sway Bar End Links (2018 & Up, JL)

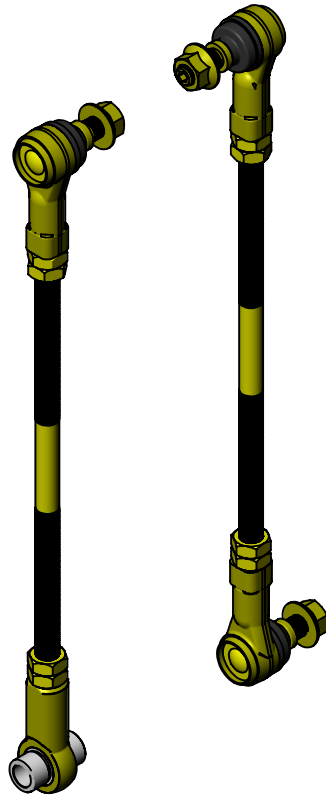

NOTES: This product may require general welding, fabrication and automotive mechanic skills. Welding should only be done by a competent welder. Clayton Off Road implies no guarantees or warranties and is not liable for improper installation. Some grinding and fitment may be required when installing this product. Every vehicle varies slightly and some fabrication may be required. For more information please visit our website.

Refer to pictures below.

Step 1: Remove old sway bar end links.

Step 2: Make sure vehicle is at ride height.

Step 3: Refer to the spread sheet below to determine how much to cut from each end of threaded rod.

Step 4: Cut threaded rod.

Step 5: Deburr end of threaded rod.

Step 6: Install two jam nuts on each end of rod.

Step 7: It maybe necessary to lock the 2 jam nuts against each other to thread rod end on.

Step 8: The rod end with no stud in it goes on the passenger side axle, Use a aluminum spacer on each side of this rod end.

Step 9: Install sway bar links with the studs facing in.

Step 10: Make sure all rod ends are centered.

Step 11: Torque all nuts, bolts and jam nuts to 60 ft-lb.

Step 12: Cycle the suspension through its full travel, check for binding and adjust rod length if needed.

Step 13: Do not exceed maximum length.

Step 14: Make sure to keep at least 3/4" of thread engagement with rod end.

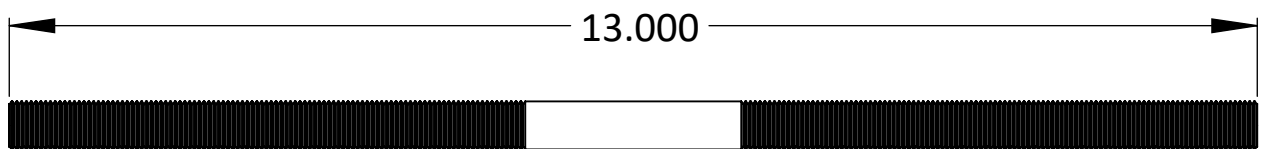

Lift Height >	Stock	2.5" Lift		3.5" Lift		4.5" Lift	
Suspension Component		Center Length	Cut Each End	Center Length	Cut Each End	Center Length	Cut Each End
JK Front Sway Bar Link	5.250	9.250	2.938	10.250	2.438	11.250	1.938
JK Rear Sway Bar Link	8.750	11.750	1.656	12.750	1.188	13.750	0.688
JL Front Sway Bar Link	5.063	9.063	3.000	10.063	2.531		
JL Rear Sway Bar Link	8.750	11.750	1.656	12.750	1.188		
JT Front Sway Bar Link	5.063	8.063	3.500	9.063	3.031		
JT Rear Sway Bar Link	10.625	13.625	0.719	14.625	0.250		

Refer to drawing below for minimum and maximum lengths.

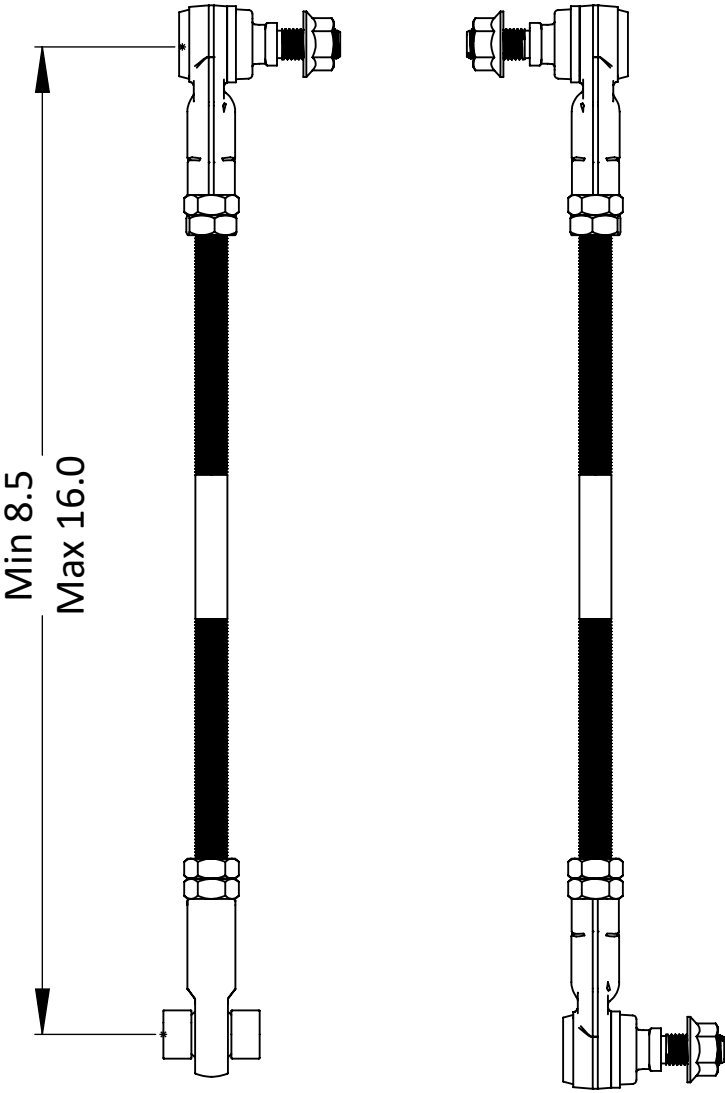

**Clayton Off Road
COR-1709103
Jeep Wrangler Overland + Rear Upper Control Arms (2007 & Up, JK/JL)**



NOTES: This product may require general welding, fabrication and automotive mechanic skills. Welding should only be done by a competent welder. Clayton Off Road implies no guarantees or warranties and is not liable for improper installation. Some grinding and fitment may be required when installing this product. Every vehicle varies slightly and some fabrication may be required. For more information please visit our website.

Refer to pictures below.

Step 1: Support axle from rotating, a floor or bottle jack works well.

Step 2: Remove old control arms.

Step 3: Set pinion angle desired pinion angle by adjusting the height of the jack.

Step 4: Install arms at frame side, arm should bow towards frame & adjuster at axle end.

Step 5: Adjust control arm to length so that bolts can easily be installed at axle end.

Step 6: Remove jack, and pinion angle.

Step 7: Torque all bolts to 95 ft-lb at axle end and 120 ft-lb at frame end.

Step 8: Tighten jam nut using a 1-7/16" wrench.

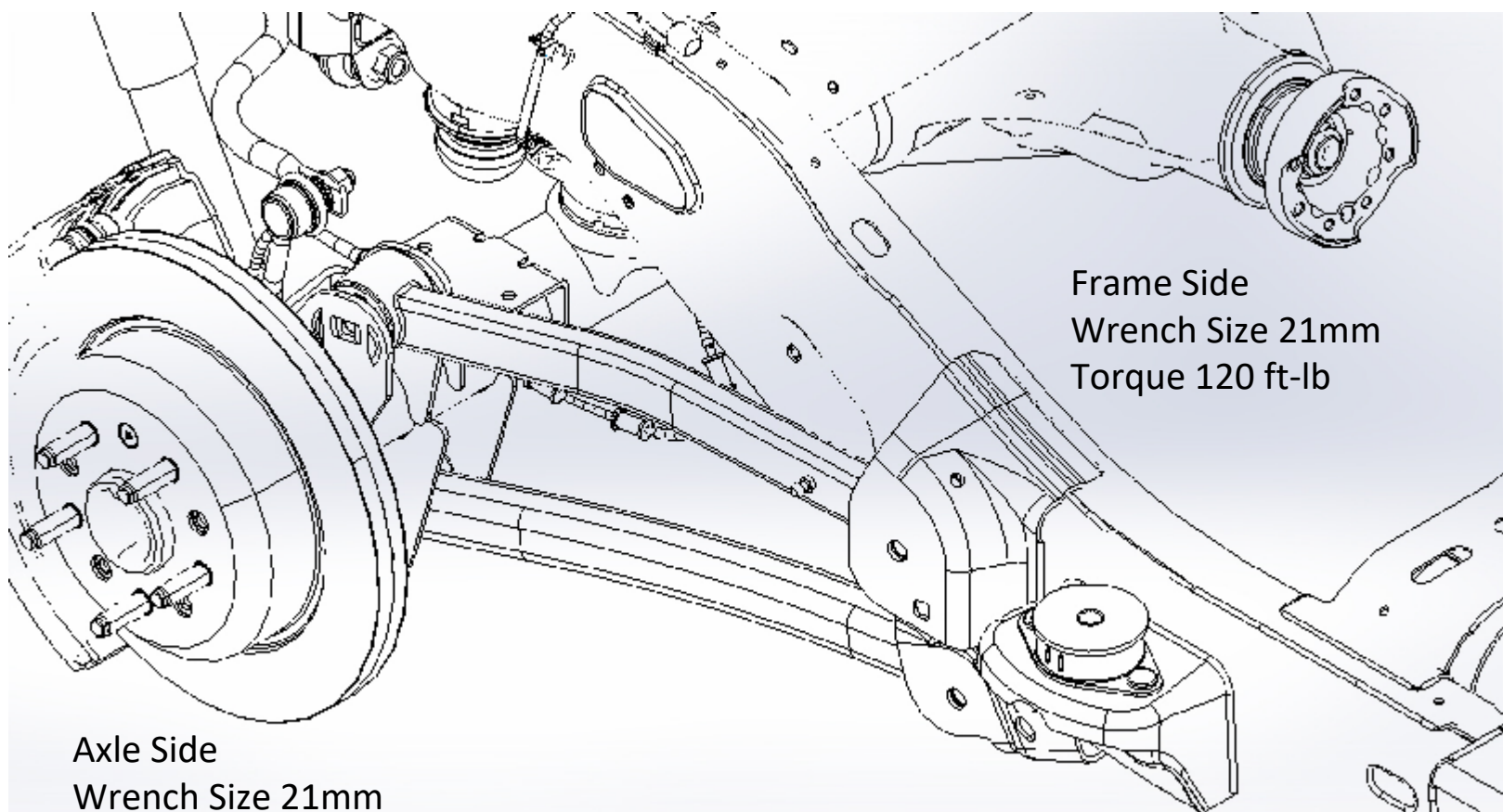

Frame Side
Wrench Size 21mm
Torque 120 ft-lb

Axle Side
Wrench Size 21mm
Torque 95 ft-lb

Refer to drawing below for minimum and maximum lengths.

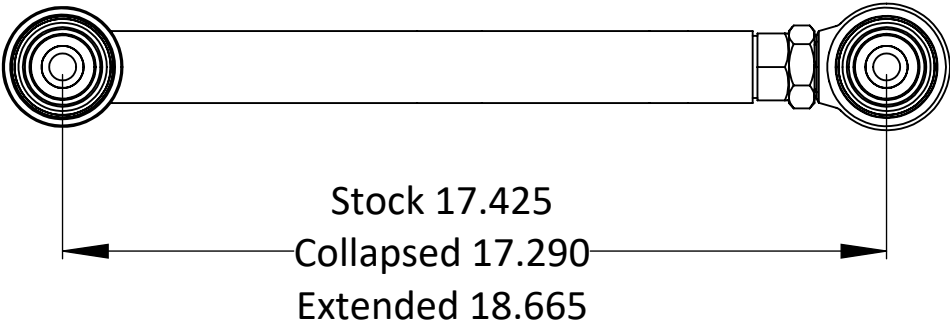

**Clayton Off Road
COR-4509110
Jeep Wrangler Adjustable Rear Track Bar (2018 & Up, JL)**

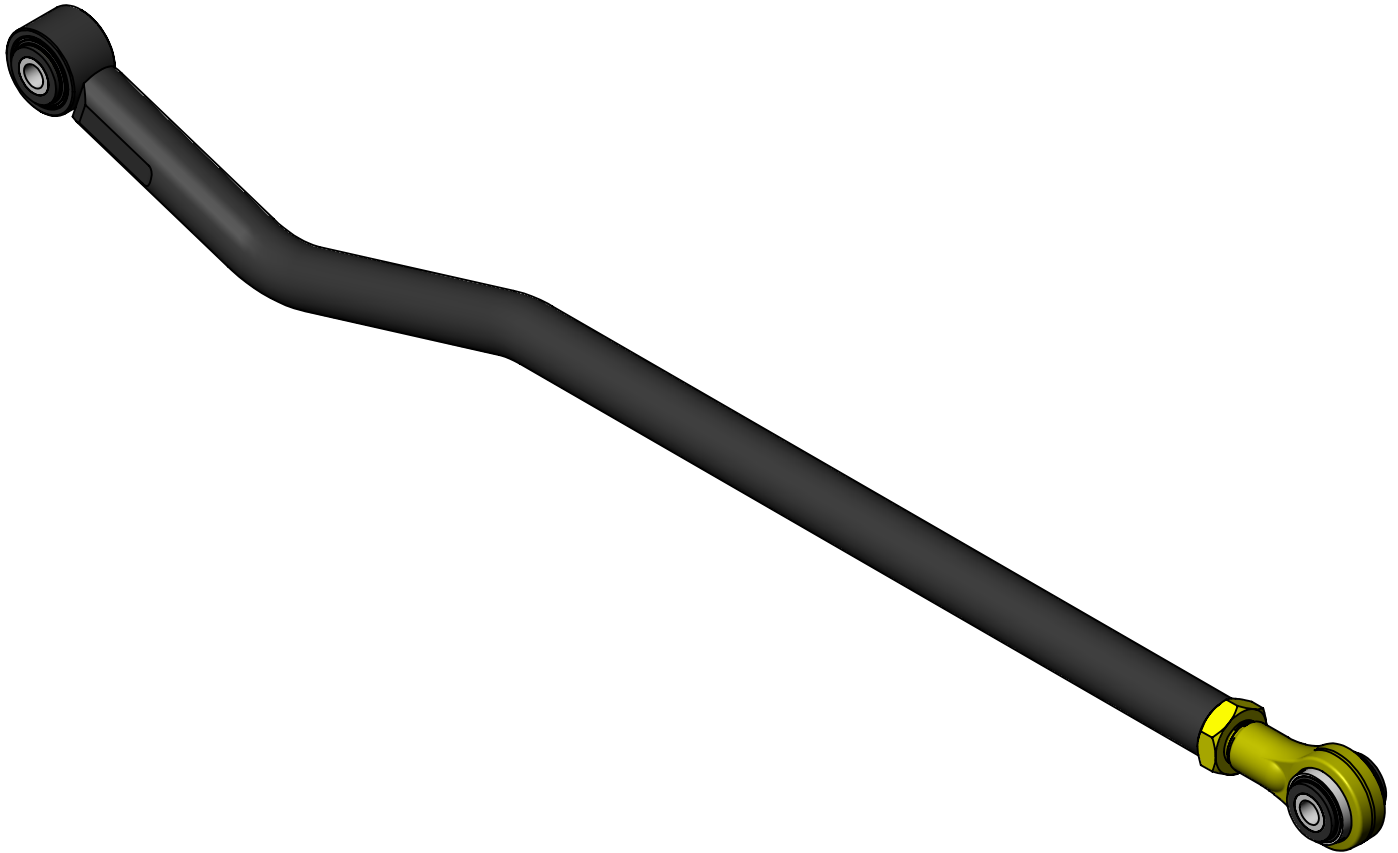

NOTES: This product may require general welding, fabrication and automotive mechanic skills. Welding should only be done by a competent welder. Clayton Off Road implies no guarantees or warranties and is not liable for improper installation. Some grinding and fitment may be required when installing this product. Every vehicle varies slightly and some fabrication may be required. For more information please visit our website.

Refer to pictures below.

Step 1: Remove old track bar.

Step 2: Center frame on axle.

Step 3: Measure length from axle side mount to frame side mount.

Step 4: Adjust track bar to length and run jam nut up to track bar tube.

Step 5: Install new track bar with adjustment end on frame side.

Step 6: Install track bar bolts and nuts.

Step 7: Torques both bolts to 90 ft-lb.

Step 8: Tighten jam nut using a 1-7/16" wrench.

Step 9: Make sure Johnny Joint at frame side is centered in bracket.

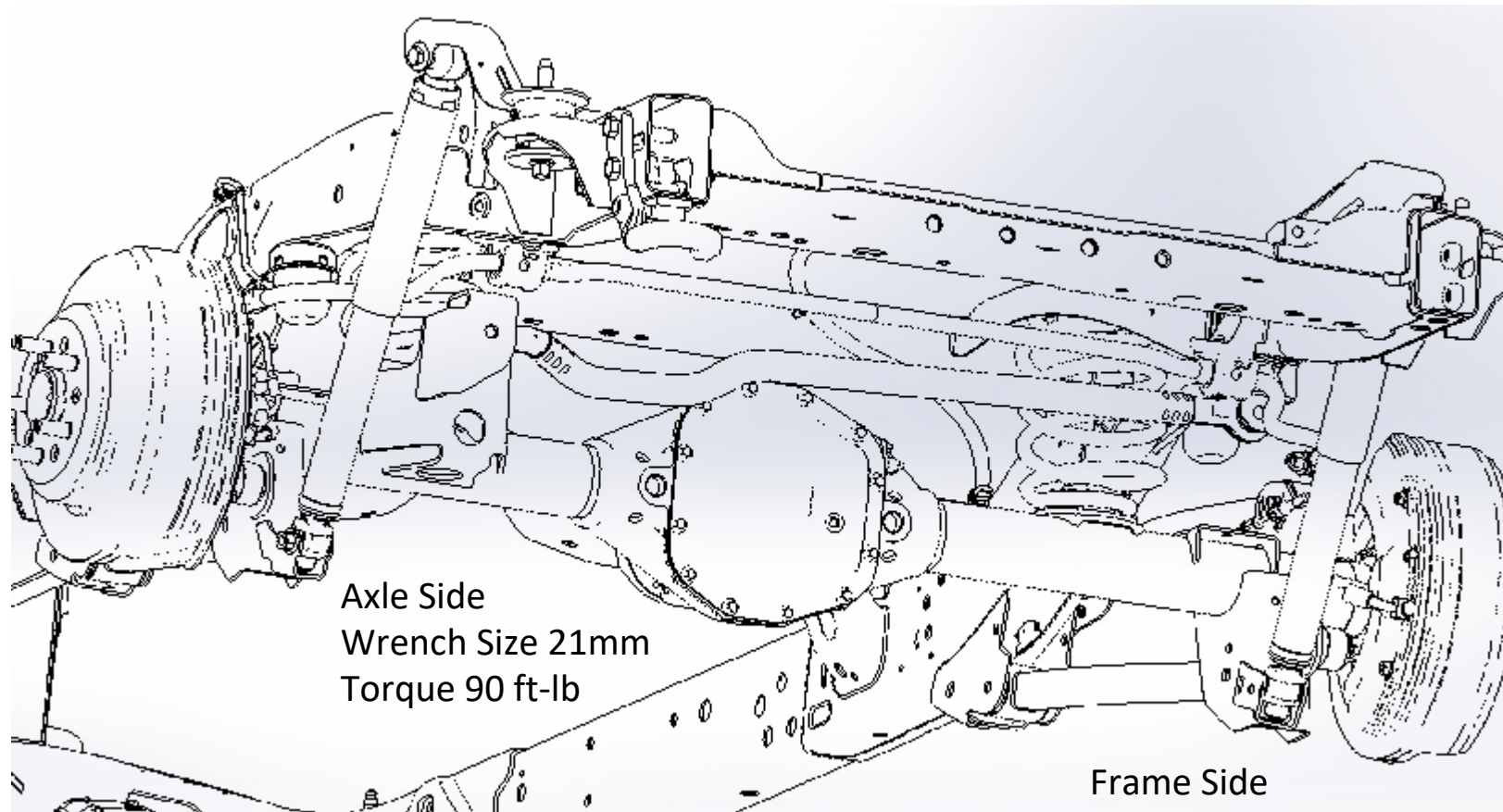

Axle Side
Wrench Size 21mm
Torque 90 ft-lb

Frame Side
Wrench Size 21mm
Torque 90 ft-lb

Refer to drawing below for minimum and maximum lengths.

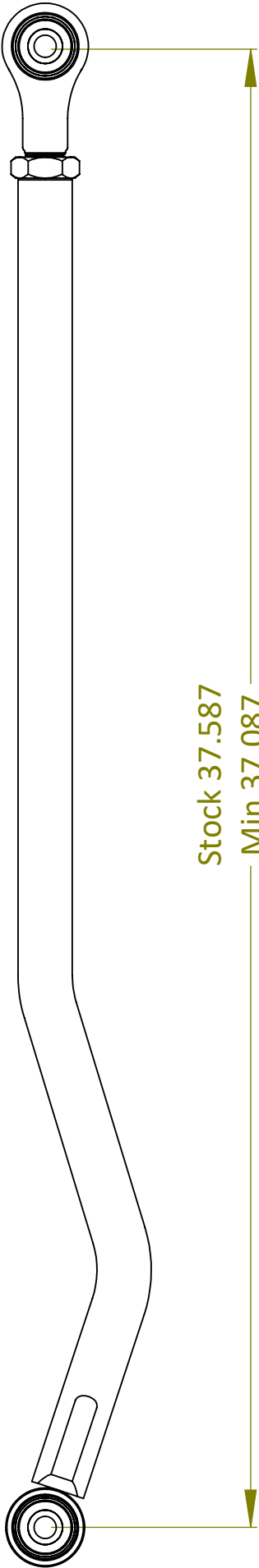

Clayton Off Road
COR-5109100
Jeep Wrangler Adjustable Rear Sway Bar End Links (2007 & Up, JK/JL)

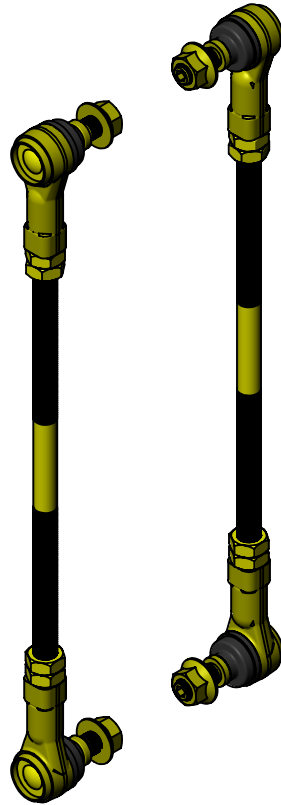

NOTES: This product may require general welding, fabrication and automotive mechanic skills. Welding should only be done by a competent welder. Clayton Off Road implies no guarantees or warranties and is not liable for improper installation. Some grinding and fitment may be required when installing this product. Every vehicle varies slightly and some fabrication may be required. For more information please visit our website.

Refer to pictures below.

Step 1: Remove old sway bar end links.

Step 2: Make sure vehicle is at ride height.

Step 3: Refer to the spread sheet below to determine how much to cut from each end of threaded rod.

Step 4: Cut threaded rod.

Step 5: Deburr end of threaded rod.

Step 6: Install two jam nuts on each end of rod.

Step 7: It maybe necessary to lock the 2 jam nuts against each other to thread rod end on.

Step 8: Install sway bar links with the studs facing in.

Step 9: Make sure all rod ends are centered.

Step 10: Torque all nuts, bolts and jam nuts to 60 ft-lb.

Step 11: Cycle the suspension through its full travel, check for binding and adjust rod length if needed.

Step 12: Do not exceed maximum length.

Step 13: Make sure to keep at least 3/4" of thread engagement with rod end.

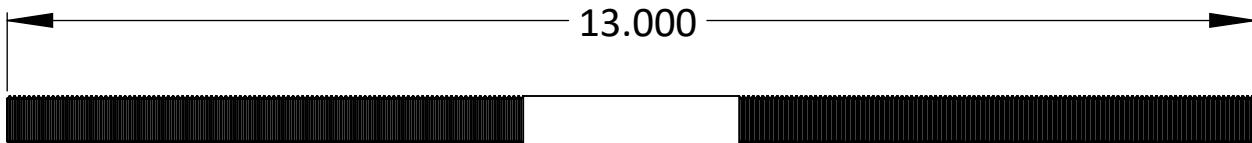

Lift Height >	Stock	2.5" Lift		3.5" Lift		4.5" Lift	
Suspension Component		Center Length	Cut Each End	Center Length	Cut Each End	Center Length	Cut Each End
JK Front Sway Bar Link	5.250	9.250	2.938	10.250	2.438	11.250	1.938
JK Rear Sway Bar Link	8.750	11.750	1.656	12.750	1.188	13.750	0.688
JL Front Sway Bar Link	5.063	9.063	3.000	10.063	2.531		
JL Rear Sway Bar Link	8.750	11.750	1.656	12.750	1.188		
JT Front Sway Bar Link	5.063	8.063	3.500	9.063	3.031		
JT Rear Sway Bar Link	10.625	13.625	0.719	14.625	0.250		

Refer to drawing below for minimum and maximum lengths.

