

**CLAYTON OFF ROAD
COR-4804041
JEEP GRAND CHEROKEE FRONT LONG ARM UPGRADE KIT (1996-1998 ZJ)**



NOTES: This product requires general welding, fabrication and automotive mechanic skills. Welding should only be done by a competent welder. Clayton Off Road implies no guarantees or warranties and is not liable for improper installation. Some grinding and fitment may be required when installing this product. Every vehicle varies slightly and some fabrication may be required. For more information please visit our web site.

Refer to individual product part number instructions.

Step 1: Install part number COR-2104610 3 piece cross member.

Step 2: Chock front and back of the driver side front wheel.

Step 3: Remove upper and lower control arms.

Step 4: Remove lower control arm bracket on frame side.

Step 5: Install driver side arm of part number COR-1900100 lower control arm.

Step 6: Install the dog legged arm of part number COR-1900011 upper control arm.

Step 7: Repeat steps 2 to 6 on the passenger side.

Notes: All final adjustments and tightening of hardware should be done with the vehicle sitting at ride height. Care should be taken to set caster and track without binding up the suspension.

**CLAYTON OFF ROAD
COR-1900011
JEEP FRONT UPPER CONTROL ARM KIT (1984-2004 TJ/LJ/XJ/ZJ/WJ)**

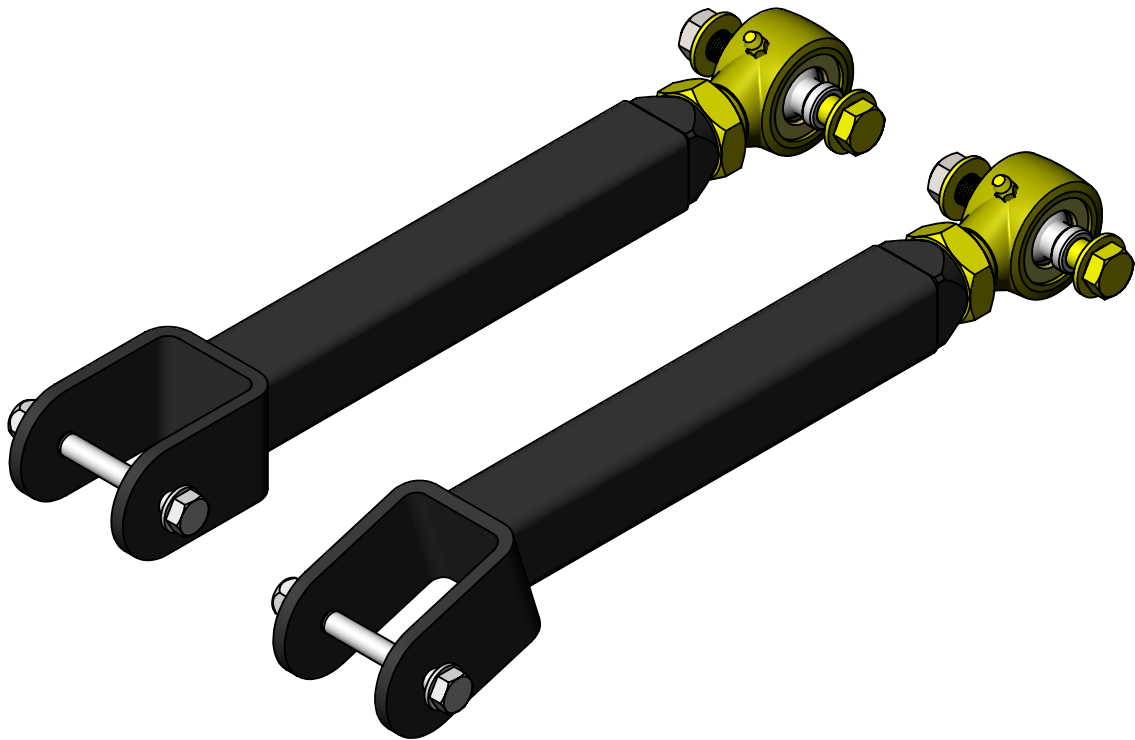

NOTES: This product may require general welding, fabrication and automotive mechanic skills. Welding should only be done by a competent welder. Clayton Off Road implies no guarantees or warranties and is not liable for improper installation. Some grinding and fitment may be required when installing this product. Every vehicle varies slightly and some fabrication may be required. For more information please visit our website.

Refer to drawing view below.

Step 1: Support axle from pivoting on lower control arms. (A bottle jack works well)

Step 2: Remove old upper control arms.

Step 3: Make sure vehicle is at ride height and track is set.

Step 4: Install new upper control arm at axle using new hardware.

Step 5: Adjust caster angle to specifications below.

Step 6: Adjust both arm length to get the bolts in on the control arm mount with grease fitting up.

Step 7: Tighten bolts.

Step 8: Tighten jam nuts. (We recommend a 1 7/16" combination wrench for this. We also recommend cutting the box end off the wrench and getting a three foot piece pipe to put over the end of the wrench for leverage. Inserting a large screw driver between the joint body and the mount will hold the housing joint straight.)

Step 9: The joints are pre greased so initial greasing is not required. (We do recommend greasing the joints every time you change your oils or grease other components on your vehicle. Use a hand grease gun not a pneumatic grease gun.)

We recommend a caster angle on the drivers side to be between 5 and 6 degrees. (Top of the inner knuckle tipped towards the rear of the vehicle)
In certain cases caster angles as low as 3 to 4 degrees are possible to get better drive shaft angles however this may effect the handling of the vehicle.
Too much caster change from the factory settings may also cause the coil springs to bow and effect clearances on the steering linkages. Keep length within the minimum and maximum lengths shown below.

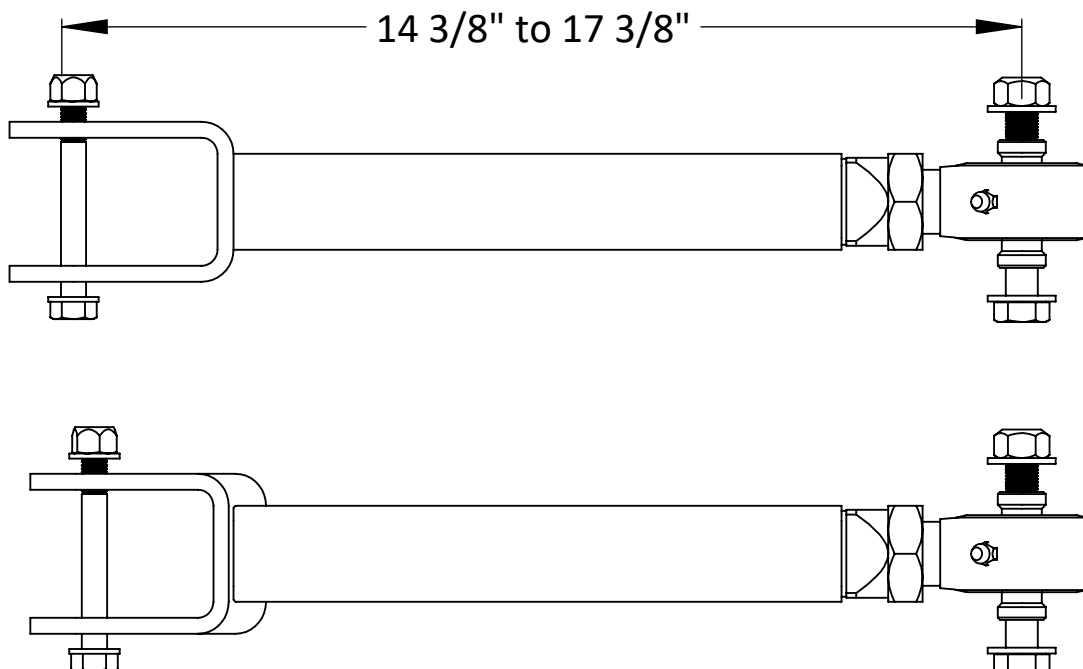

**CLAYTON OFF ROAD
COR-1900100
JEEP LONG FRONT LOWER CONTROL ARMS (1984-2006 TJ/LJ/XJ/ZJ)**



NOTES: This product may require general welding, fabrication and automotive mechanic skills. Welding should only be done by a competent welder. Clayton Off Road implies no guarantees or warranties and is not liable for improper installation. Some grinding and fitment may be required when installing this product. Every vehicle varies slightly and some fabrication may be required. For more information please visit our website.

Refer to drawing view below and individual product part number instructions.

Step 1: Set one arm as close to recommended length as possible with grease fitting down.

Step 2: Set second arm to same length with grease fitting down. (Use two 9/16" bolts in each end of both arms.)

Step 3: Bolt control arm into cross member.

Step 4: Bolt control arm into axle.

Step 5: Repeat steps 3 and 4 on other side.

Step 6: Tighten bolts after vehicle is sitting at ride height.

Step 7: Tighten jam nuts. (We recommend a 46 mm or 1 13/16" combination wrench for this. We also recommend cutting the box end off the wrench and getting a three foot piece pipe to put over the end of the wrench for leverage. Inserting a large screw driver between the joint body and the mount will hold the housing joint straight.)

Step 8: The joints are pre greased so initial greasing is not required. (We do recommend greasing the joints every time you change your oils or grease other components on your vehicle. Use a hand grease gun not a pneumatic grease gun.)

Step 9: Remove grease fittings and install set screws.

Recommended control arm length for 4.0" to 7.0" of lift is 36".

Some adjustment of this measurement maybe performed for special applications as long as the length stays within the minimum and maximum lengths shown below.

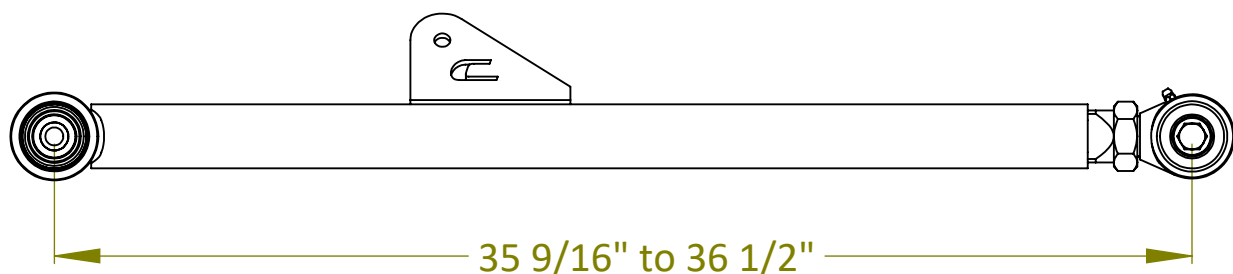

**CLAYTON OFF ROAD
COR-2104610
JEEP GRAND CHEROKEE FRONT 3 PIECE CROSS MEMBER (1993-1998, ZJ)**

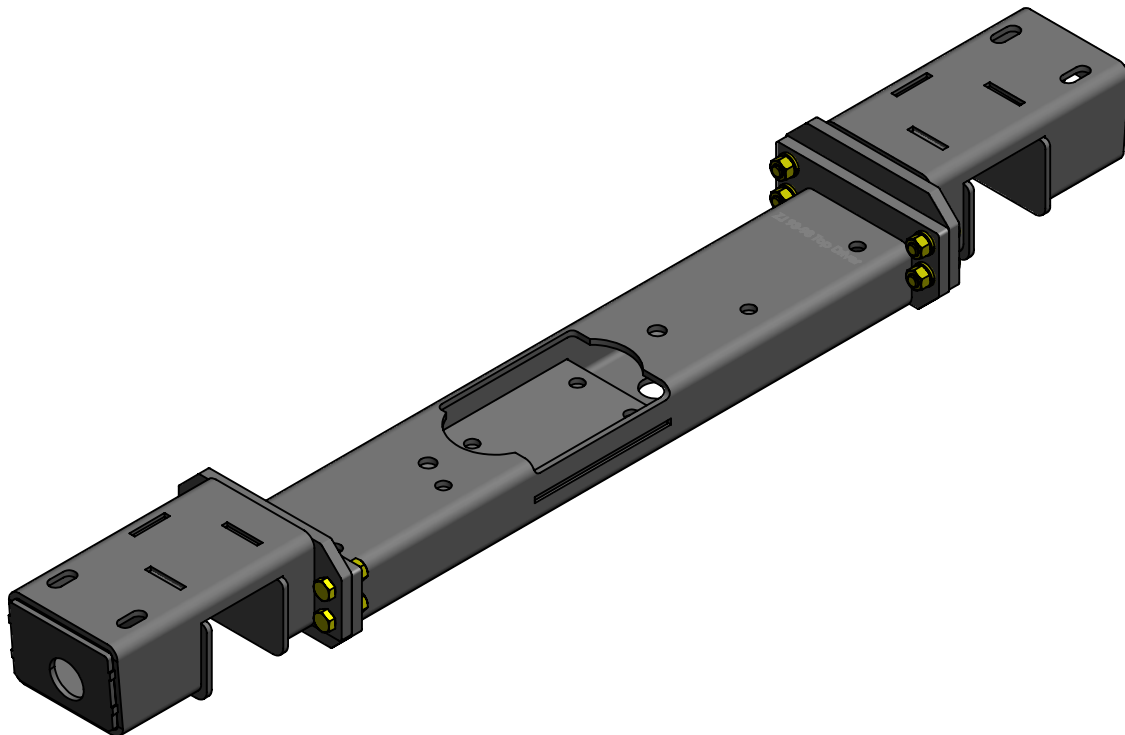

NOTES: This product requires general welding, fabrication and automotive mechanic skills. Welding should only be done by a competent welder. Clayton Off Road implies no guarantees or warranties and is not liable for improper installation. Some grinding and fitment may be required when installing this product. Every vehicle varies slightly and some fabrication may be required. For more information please visit our web site.

Refer to drawing views.

Step 1: Assembly cross member as shown.

Step 2: If you have a 96-98 model year slide transmission mount into cross member and weld in place using the slots in the cross member. Be sure to lineup with the access holes in cross member.

Step 3: Support vehicle drive line.

Step 4: Remove old cross member.

Step 5: Clean frame for welding.

Step 6: Lightly bolt new cross member into place.

Step 7: Square and center cross member.

Step 8: Tighten bolts.

Step 9: Weld both sides along the front, back & end.

Step 10: Bolt transmission mount in.

Step 11: Weld end caps on with access holes aligned.

Step 12: Paint cross member.

