

**CLAYTON OFF ROAD  
COR-4806011  
JEEP GRAND CHEROKEE LONG ARM UPGRADE KIT (1999-2004 WJ)**



NOTES: This product requires general welding, fabrication and automotive mechanic skills. Welding should only be done by a competent welder. Clayton Off Road implies no guarantees or warranties and is not liable for improper installation. Some grinding and fitment may be required when installing this product. Every vehicle varies slightly and some fabrication may be required. For more information please visit our web site.

Refer to individual product part number instructions.

Step 1: Install part number COR-2106110 3 piece cross member.

Step 2: Install part number COR-2206110 rear frame brackets.

Step 3: Install part number COR-2206210 uni-body frame rails.

Step 4: Chock front and back of the driver side front wheel.

Step 5: Remove upper and lower control arms.

Step 6: Remove lower control arm bracket on frame side.

Step 7: Install driver side arm of part number COR-1906100 lower control arm.

Step 8: Install the dog legged arm of part number COR-1900011 upper control arm.

Step 9: Repeat steps 4 to 8 on the passenger side.

Step 10: Chock front and back of both rear wheels.

Step 11: Support axle to maintain pinion angle.

Step 12: Remove upper control arm and arm ball joint.

Step 13: Install part number COR-1206010 axle truss or COR-1206100 4-link bracket.

Step 14: Remove one lower control arm.

Step 15: Remove lower control arm bracket on frame side.

Step 16: Install one of part number COR-1906101 lower control arm.

Step 17: Repeat steps 14 to 16 on opposite side.

Step 18: Install part number COR-1900102 rear upper control arms.

Notes: All final adjustments and tightening of hardware should be done with the vehicle sitting at ride height. Care should be taken to set caster and track without binding up the suspension.

**CLAYTON OFF ROAD  
COR-2106110  
JEEP GRAND CHEROKEE FRONT 3 PIECE CROSS MEMBER (1999-2004 WJ)**

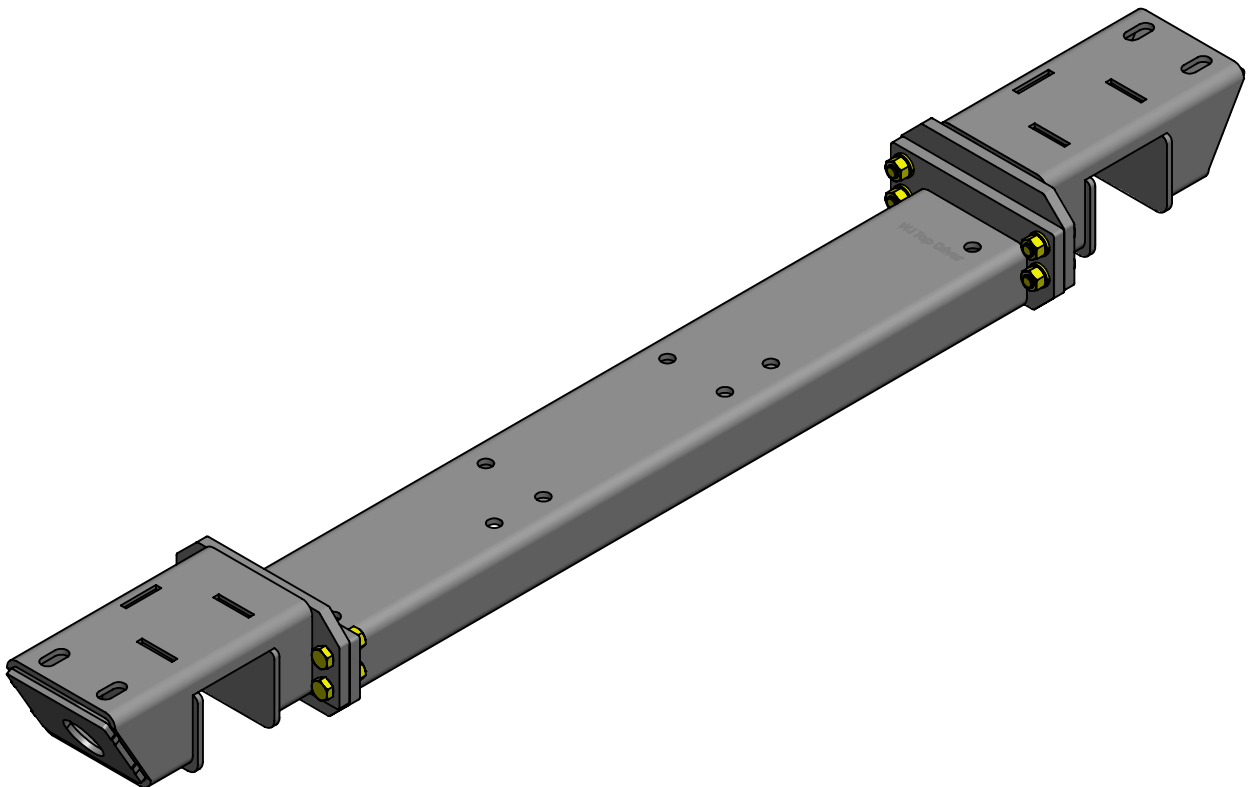

NOTES: This product requires general welding, fabrication and automotive mechanic skills. Welding should only be done by a competent welder. Clayton Off Road implies no guarantees or warranties and is not liable for improper installation. Some grinding and fitment may be required when installing this product. Every vehicle varies slightly and some fabrication may be required. For more information please visit our web site.

Refer to drawing views.

- Step 1: Assembly cross member as shown.
- Step 2: Support vehicle drive line.
- Step 3: Remove old cross member.
- Step 4: Trim flange off from rocker panel.
- Step 5: Clean frame for welding.
- Step 6: Lightly bolt new cross member into place.
- Step 7: Square and center cross member.
- Step 8: Tighten bolts.
- Step 9: Weld both sides along the front, back & end.
- Step 10: Bolt transmission mount with new hardware.
- Step 11: Weld end caps on with access holes aligned.
- Step 12: Paint cross member.

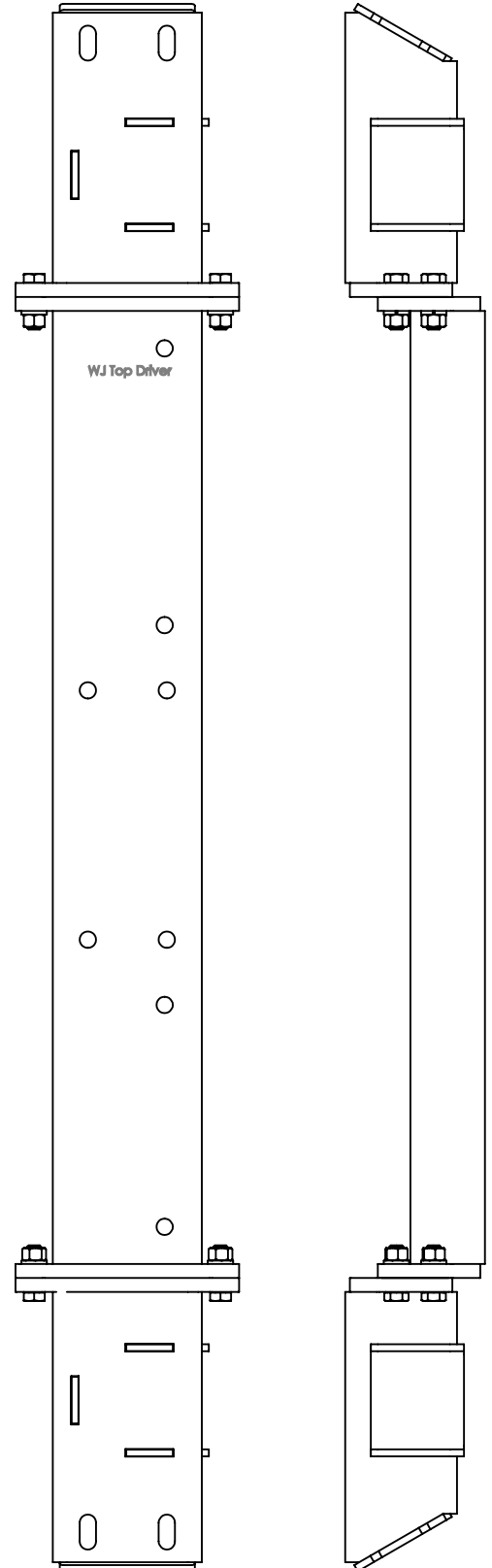

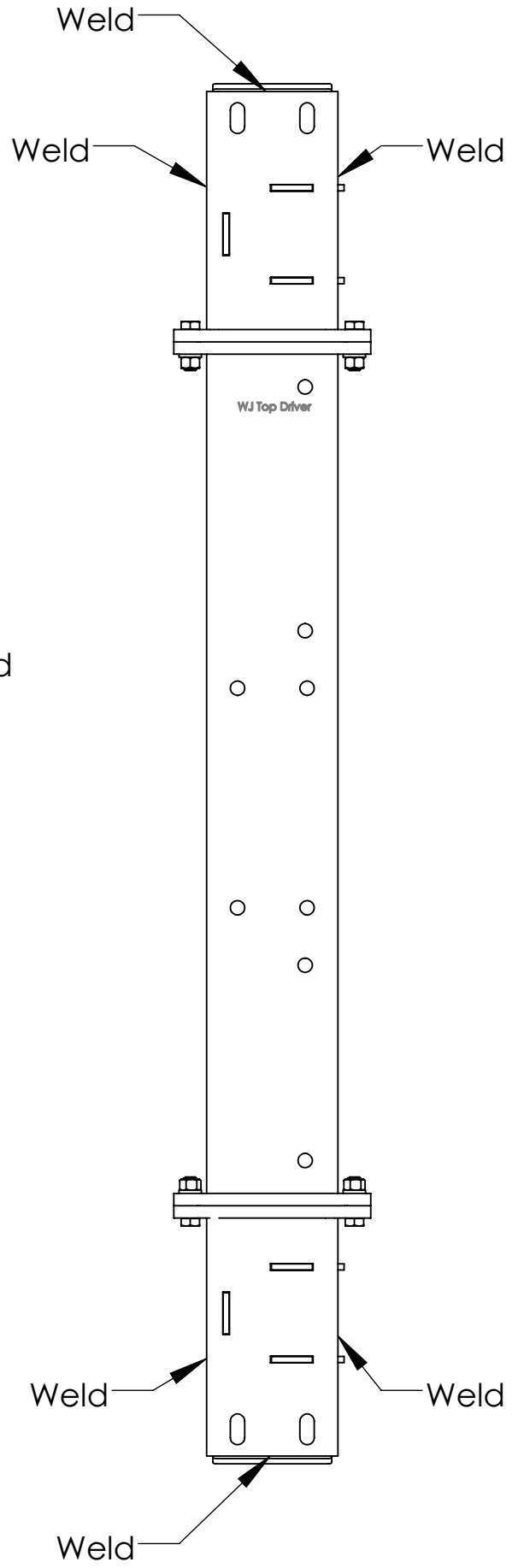
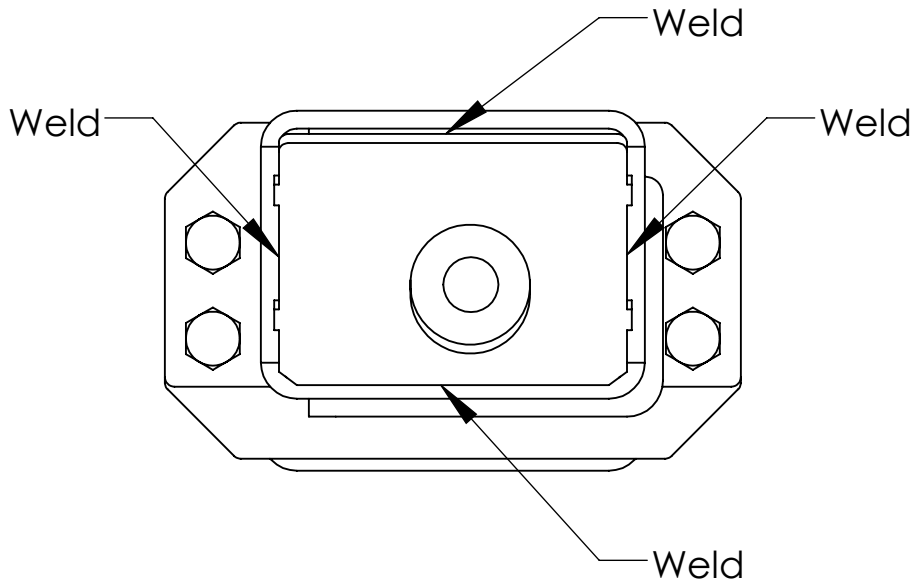

**CLAYTON OFF ROAD  
COR-2206110  
JEEP GRAND CHEROKEE REAR FRAME BRACKETS (1999-2004 WJ)**

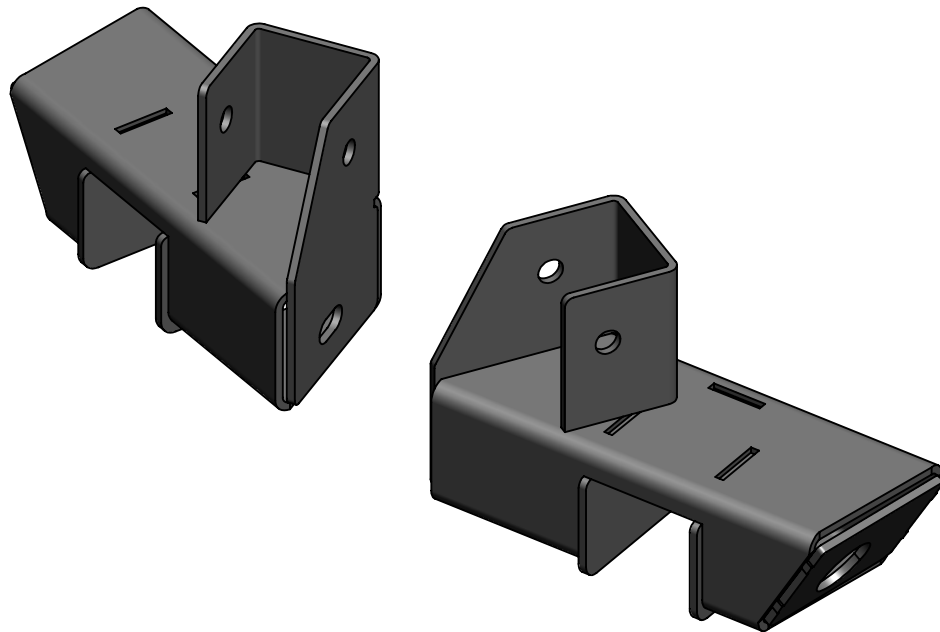

NOTES: This product requires general welding, fabrication and automotive mechanic skills. Welding should only be done by a competent welder. Clayton Off Road implies no guarantees or warranties and is not liable for improper installation. Some grinding and fitment may be required when installing this product. Every vehicle varies slightly and some fabrication may be required.

For more information please visit our web site.

Refer to drawing views.

Step 1: Install part number COR-2106110 3 piece cross member.

Step 2: Clean frame for welding.

Step 3: Locate brackets according to dimensions given. Wood blocks and a bottle jack work well for holding the brackets in place.

Step 4: Check fitment of WJ uni-body sub frame rails. Leaving about 1/8" gap is helpful during the install.

Step 5: Tack weld 4 corners of brackets.

Step 6: Weld around all 4 sides of the bracket.

Step 7: Weld end caps on with access holes aligned.

Step 8: Paint frame brackets.

Note: It is possible to use these brackets without part number COR-2106110 and measure from the stock cross member. We recommend using part number COR-2206210 to reinforce the brackets.

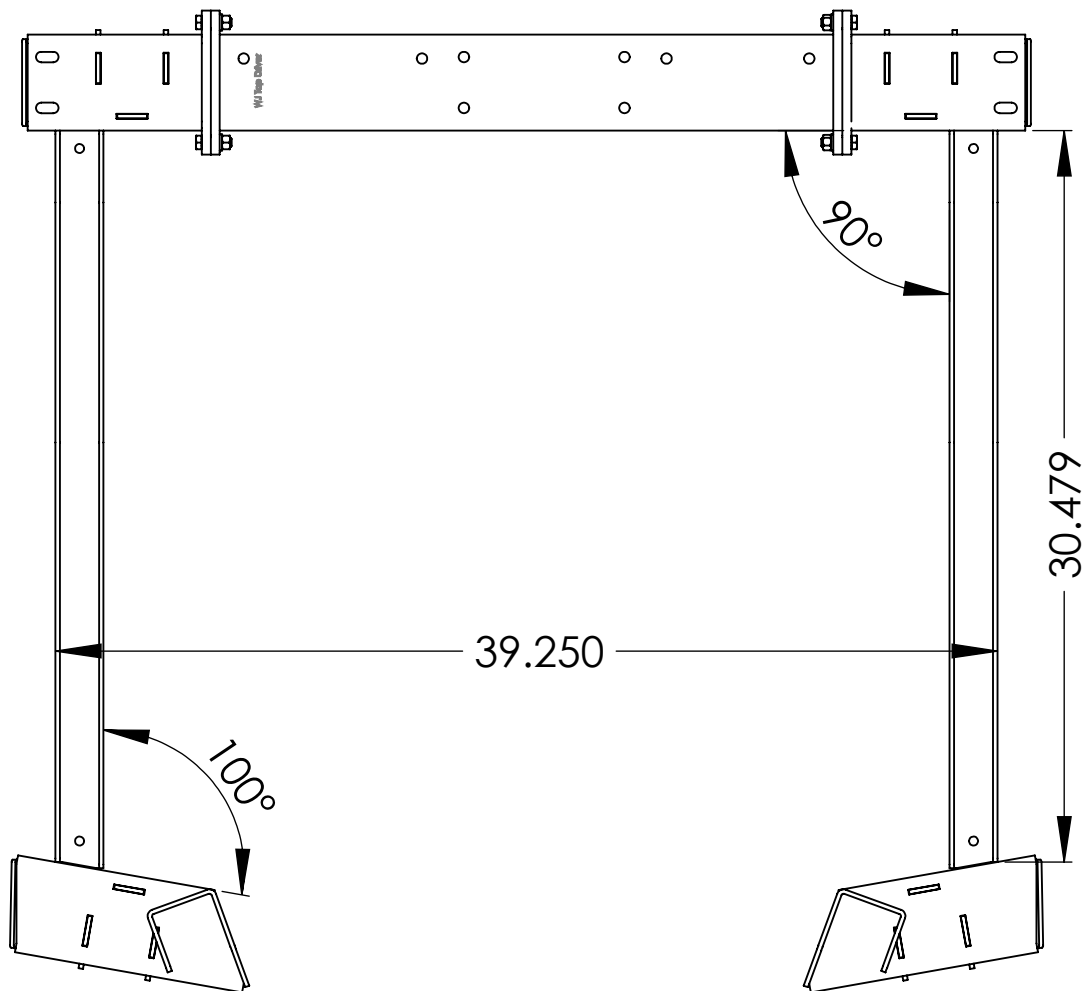

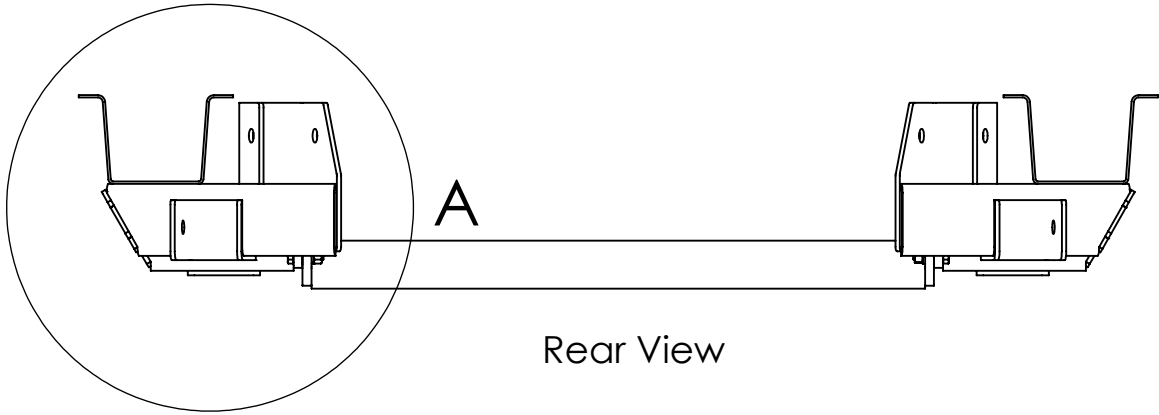

Rear View

Align edge of  
bracket with frame

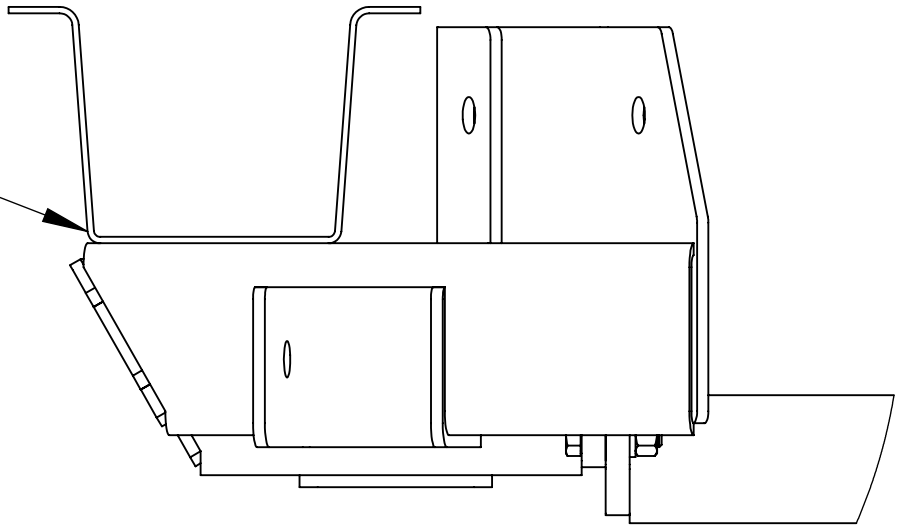

DETAIL A

SCALE 1 : 3



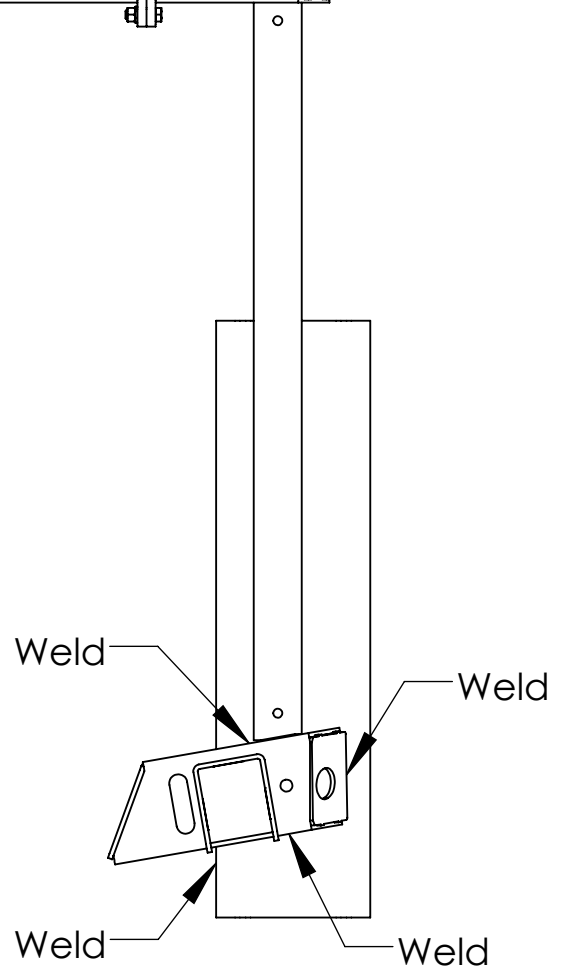
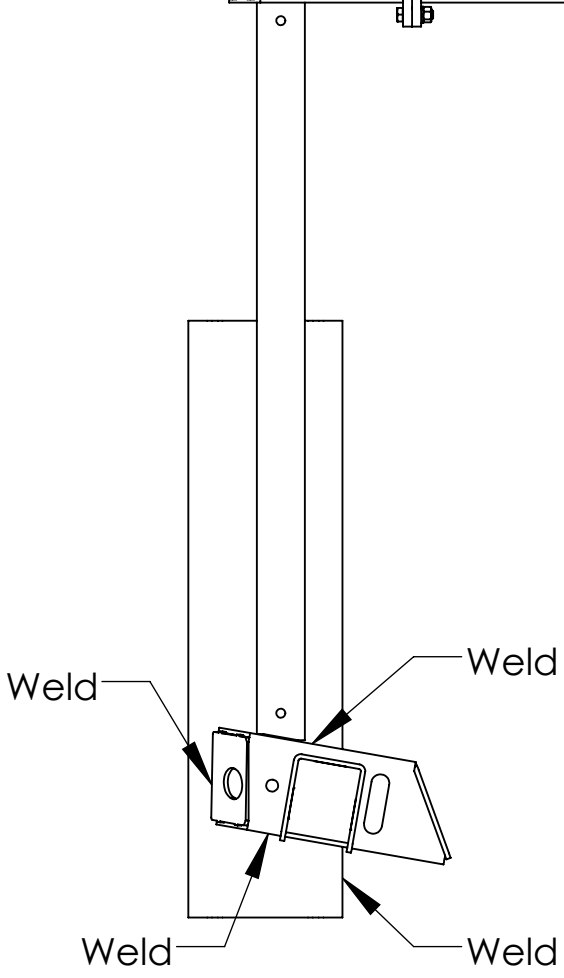
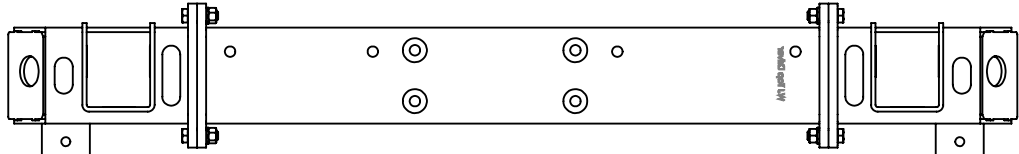

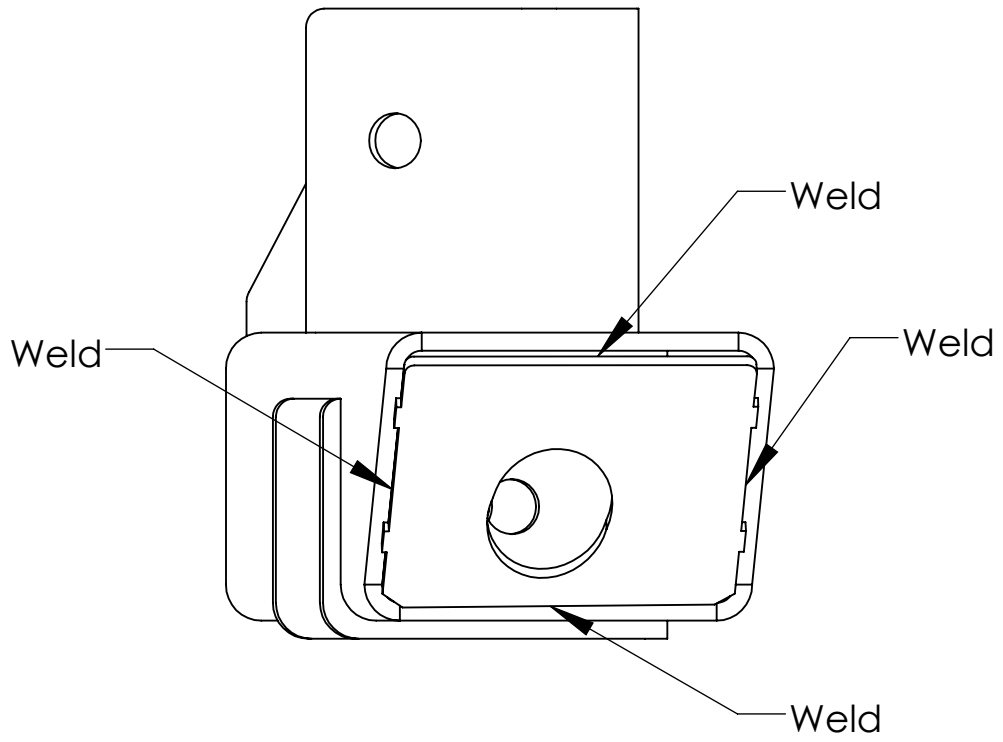

**CLAYTON OFF ROAD  
COR-2206210  
JEEP GRAND CHEROKEE UNI-BODY FRAME RAILS (1999-2004 WJ)**

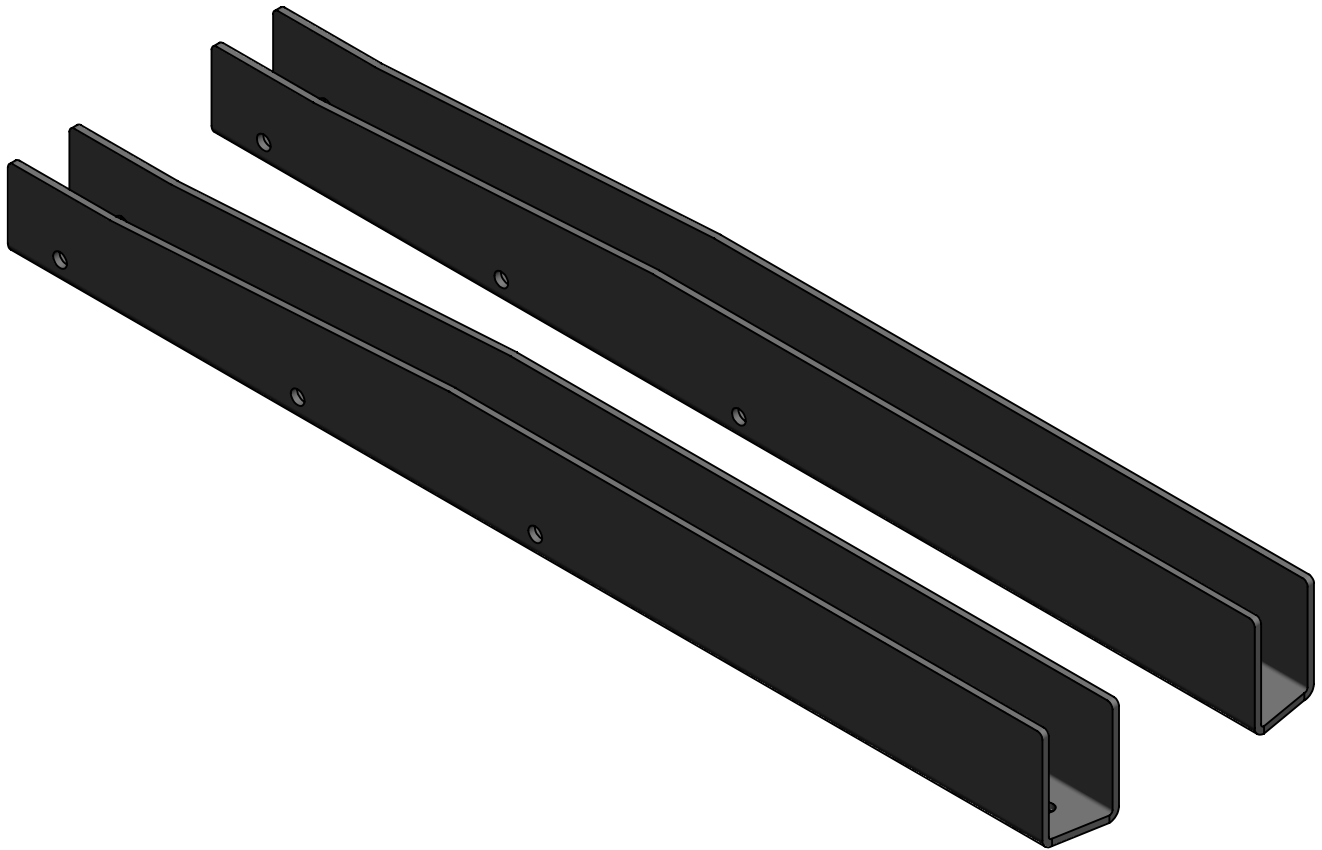

NOTES: This product requires general welding, fabrication and automotive mechanic skills. Welding should only be done by a competent welder. Clayton Off Road implies no guarantees or warranties and is not liable for improper installation. Some grinding and fitment may be required when installing this product. Every vehicle varies slightly and some fabrication may be required.

For more information please visit our web site.

Refer to drawing views for measurements.

Step 1: Install part number COR-2106110 3 piece cross member.

Step 2: Install part number COR-2206110 rear frame brackets.

Step 1: Clean frame for welding.

Step 2: Locate rails according to dimensions given. Wood blocks and a bottle jack work well for holding the rails in place.

Step 3: Check fitment with WJ 1/4" transfer case skid plate if using.

Step 4: Tack weld 4 corners of rails.

Step 5: Weld around 3 sides of the end of the rails.

Step 6: Weld along the insides and outside of the rails. Min. 6 welds spaced out.

Step 6: Paint sub frame rails.

Note: These frame rails can be installed alone but will interfere with installing other parts of our system in the future.

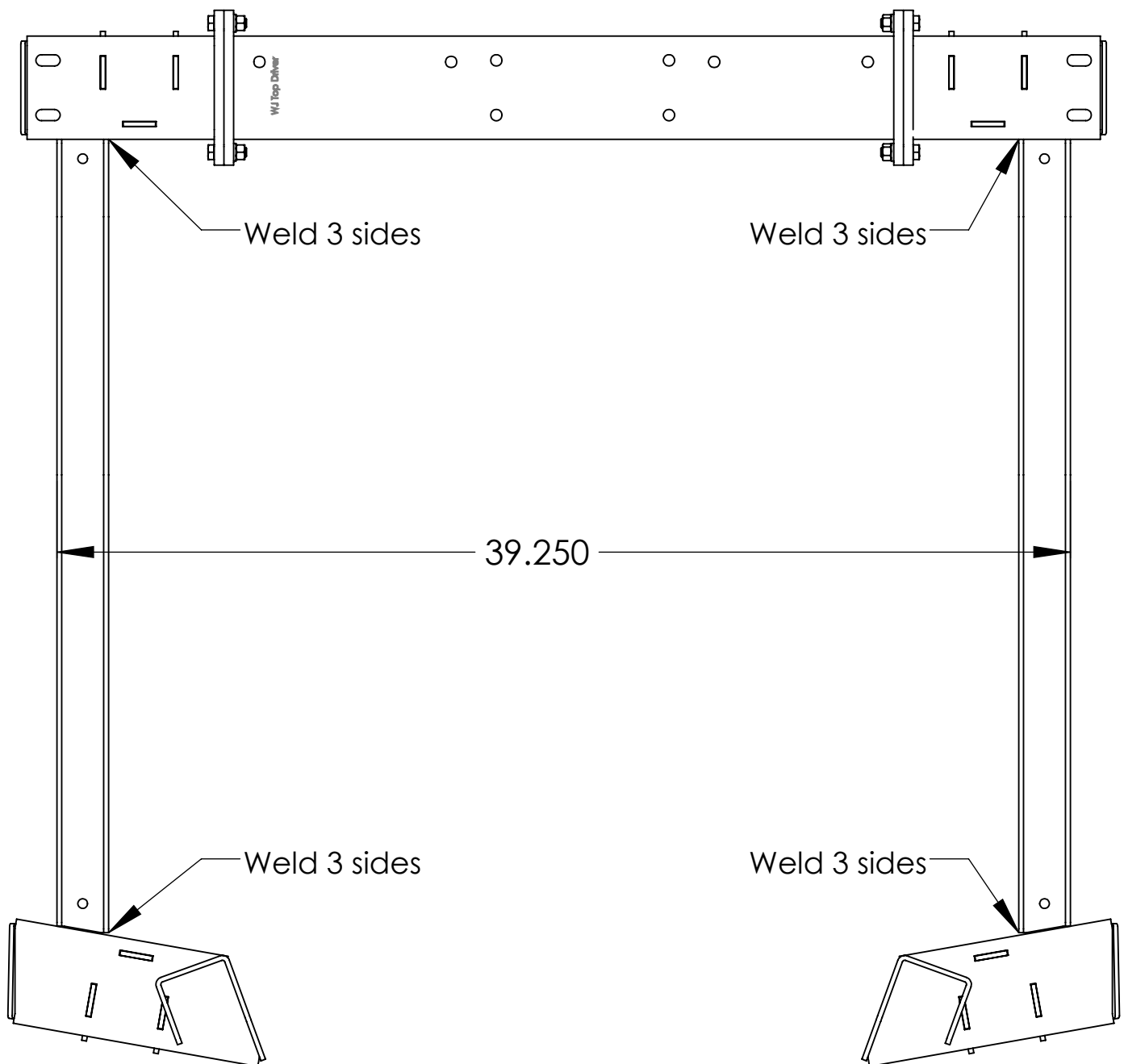

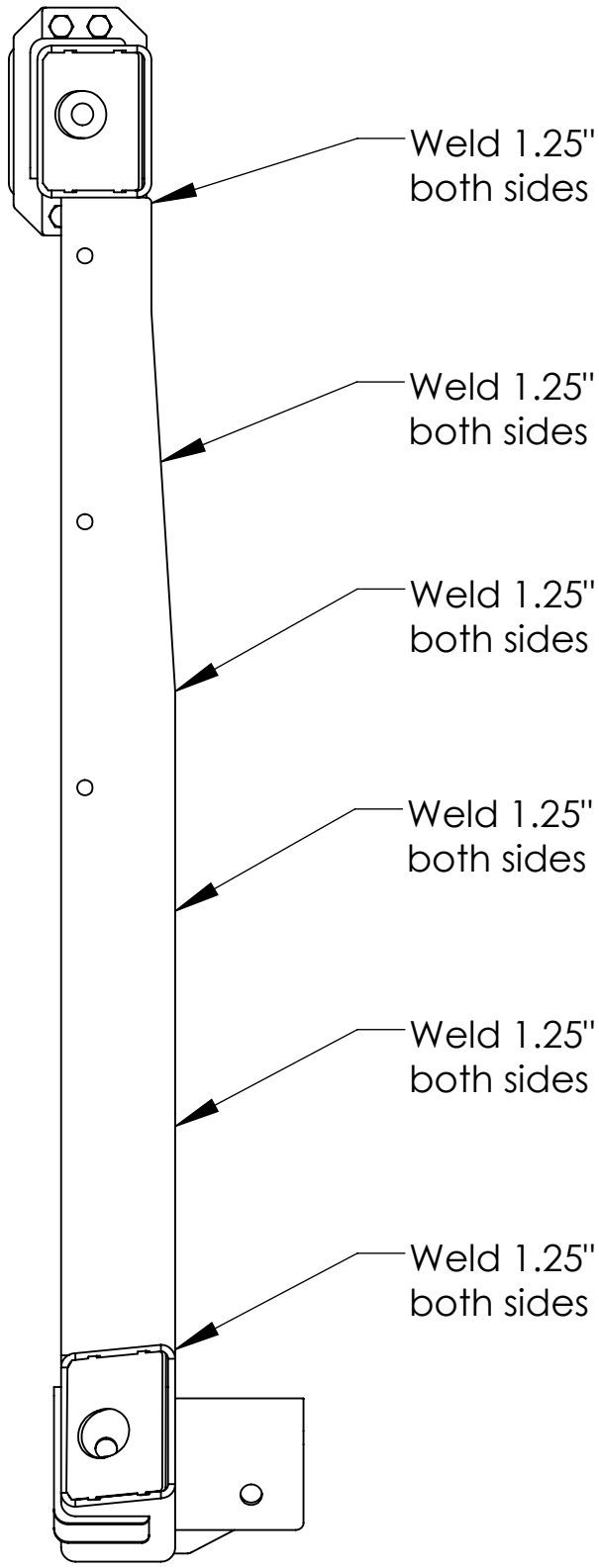

**CLAYTON OFF ROAD  
COR-1206104  
JEEP GRAND CHEROKEE CONTROL ARM SPACER KIT (1999-2004 WJ)**

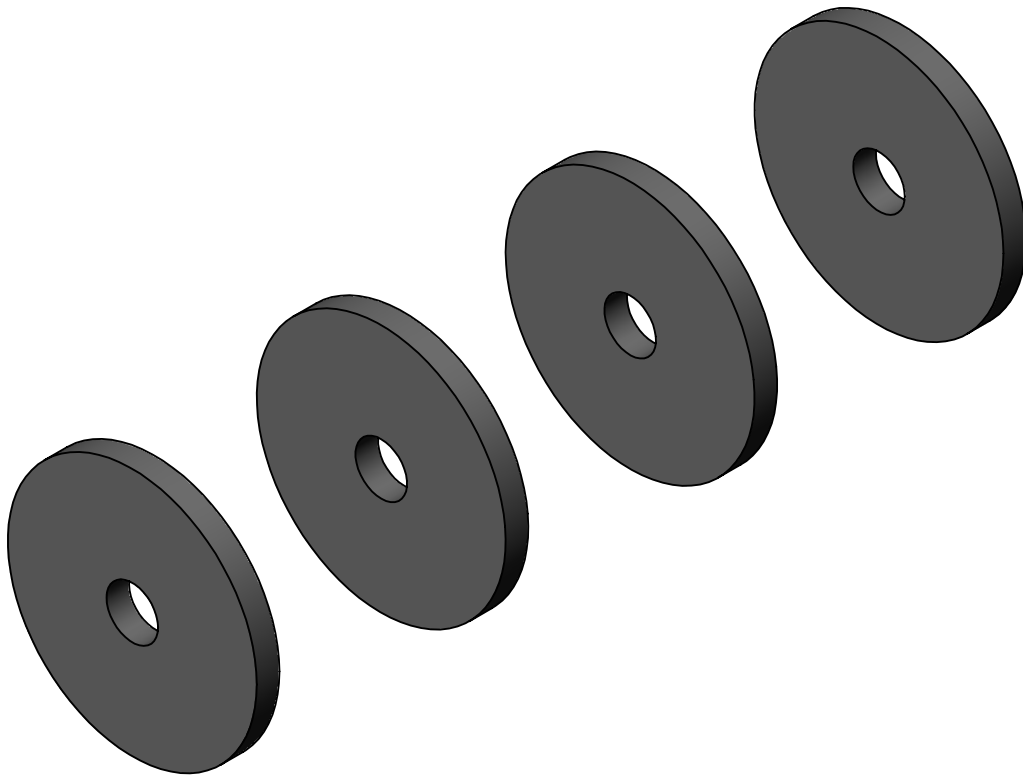

NOTES: This product may require general welding, fabrication and automotive mechanic skills. Welding should only be done by a competent welder. Clayton Off Road implies no guarantees or warranties and is not liable for improper installation. Some grinding and fitment may be required when installing this product. Every vehicle varies slightly and some fabrication may be required.

For more information please visit our website.

Refer to pictures below and drawing views.

Step 1: Remove stock control arm.

Step 2: Bolt new control arm and spacers into control arm bracket.

Step 3: Tack weld spacers to bracket.

Step 4: Remove new control arm.

Step 5: Weld spacer to bracket. Three one inch beads ar enough.

Step 6: Paint axle bracket.

Step 7: Install new control arm.



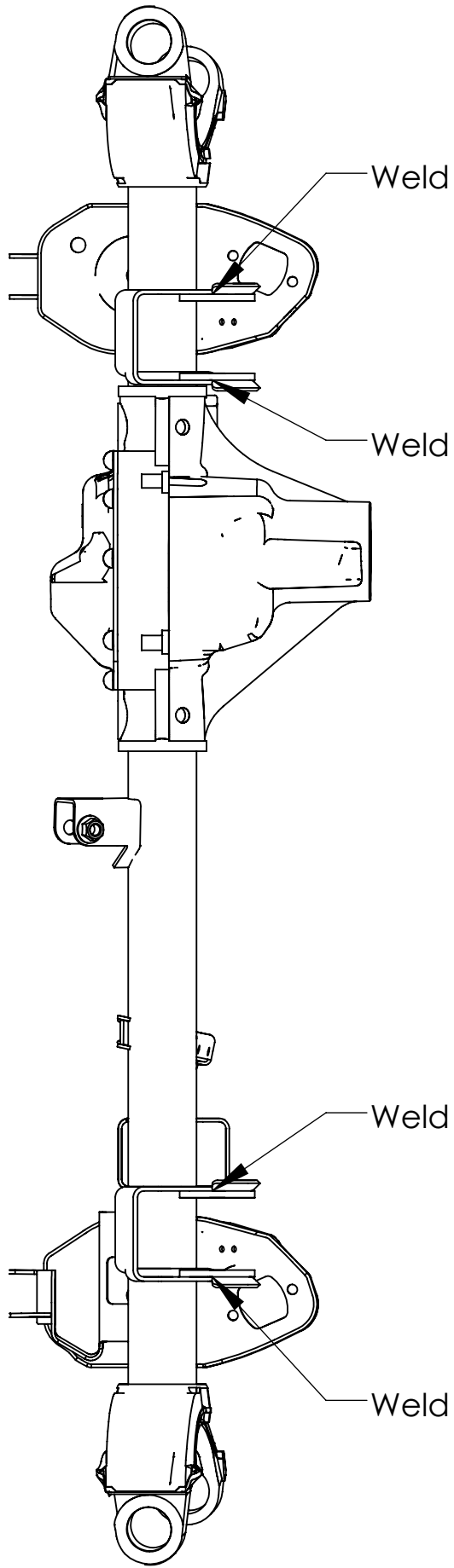



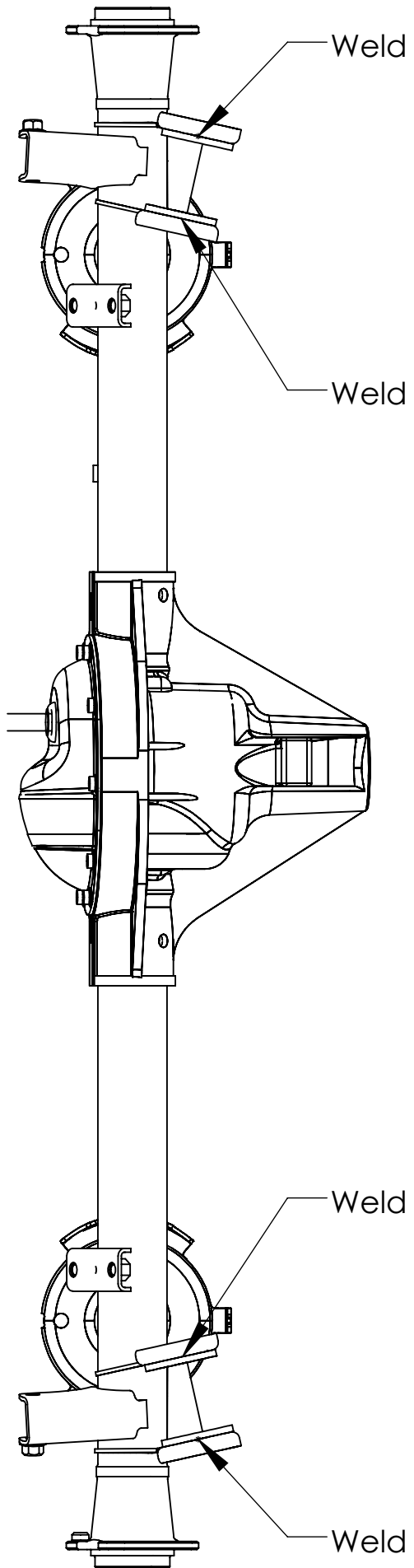

CLAYTON OFF ROAD  
COR-1906100  
JEEP GRAND CHEROKEE LONG FRONT LOWER CONTROL ARMS (1999-2004 WJ)



NOTES: This product may require general welding, fabrication and automotive mechanic skills. Welding should only be done by a competent welder. Clayton Off Road implies no guarantees or warranties and is not liable for improper installation. Some grinding and fitment may be required when installing this product. Every vehicle varies slightly and some fabrication may be required.

For more information please visit our website.

Refer to drawing view below and individual product part number instructions.

Step 1: Set one arm as close to recommended length as possible with grease fitting down.

Step 2: Set second arm to same length with grease fitting down. (Use two 9/16" bolts in each end of both arms.)

Step 3: Install part number COR-1206104 control arm spacer kit.

Step 4: Bolt control arm into cross member.

Step 5: Repeat steps 3 and 8 on other side.

Step 6: Tighten bolts after vehicle is sitting at ride height.

Step 7: Tighten jam nuts. (We recommend a 46 mm or 1 13/16" combination wrench for this. We also recommend cutting the box end off the wrench and getting a three foot pieces pipe to put over the end of the wrench for leverage. Inserting a large screw driver between the joint body and the mount will hold the housing joint straight.)

Step 8: The joints are per greased so initial greasing is not required. (We do recommend greasing the joints every time you change your oils or grease other components on your vehicle. Use a hand grease gun not a pneumatic grease gun.

Step 13: Remove grease fittings and install set screws.

**Recommended control arm length for 4.5" to 6.0" of lift is 36".  
Some adjustment of this measurement maybe performed for special applications as long as the length stays within the minimum and maximum lengths shown below.**

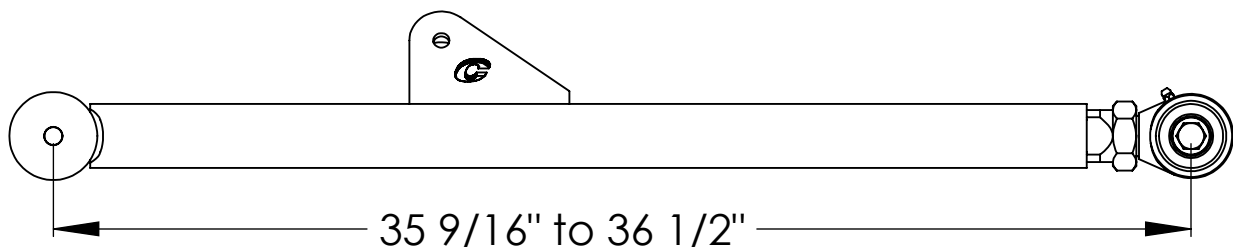

CLAYTON OFF ROAD  
COR-1900011  
JEEP FRONT UPPER CONTROL ARM KIT (1984-2004 TJ/LJ/XJ/ZJ/WJ)

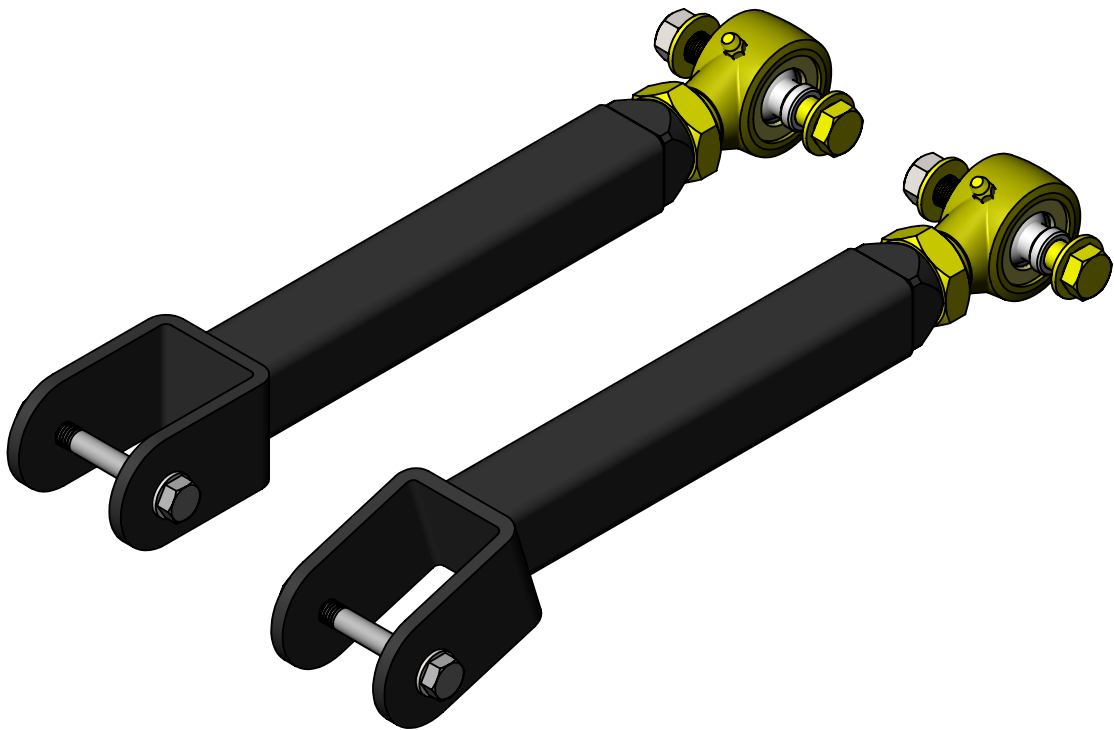

NOTES: This product may require general welding, fabrication and automotive mechanic skills. Welding should only be done by a competent welder. Clayton Off Road implies no guarantees or warranties and is not liable for improper installation. Some grinding and fitment may be required when installing this product. Every vehicle varies slightly and some fabrication may be required.

For more information please visit our website.

Refer to drawing view below.

Step 1: Support axle from pivoting on lower control arms. (A bottle jack works well)

Step 2: Remove old upper control arms.

Step 3: Make sure vehicle is at ride height and track is set.

Step 4: Install new upper control arm at axle using new hardware.

Step 5: Adjust caster angle to specifications below.

Step 6: Adjust both arm length to get the bolts in on the control arm mount with grease fitting up.

Step 7: Tighten bolts.

Step 8: Tighten jam nuts. (We recommend a 1 7/16" combination wrench for this. We also recommend cutting the box end off the wrench and getting a three foot pieces pipe to put over the end of the wrench for leverage. Inserting a large screw driver between the joint body and the mount will hold the housing joint straight.)

Step 9: The joints are pre greased so initial greasing is not required. (We do recommend greasing the joints every time you change your oils or grease other components on your vehicle. Use a hand grease gun not a pneumatic grease gun.)

**We recommend a caster angle on the drivers side to be between 5 and 6 degrees. (Top of the inner knuckle tipped towards the rear of the vehicle)**  
**In certain cases caster angles as low as 3 to 4 degrees are possible to get better drive shaft angles however this may effect the handling of the vehicle.**  
**Too much caster change from the factory settings may also cause the coil springs to bow and effect clearances on the steering linkages. Keep length within the minimum and maximum lengths shown below.**

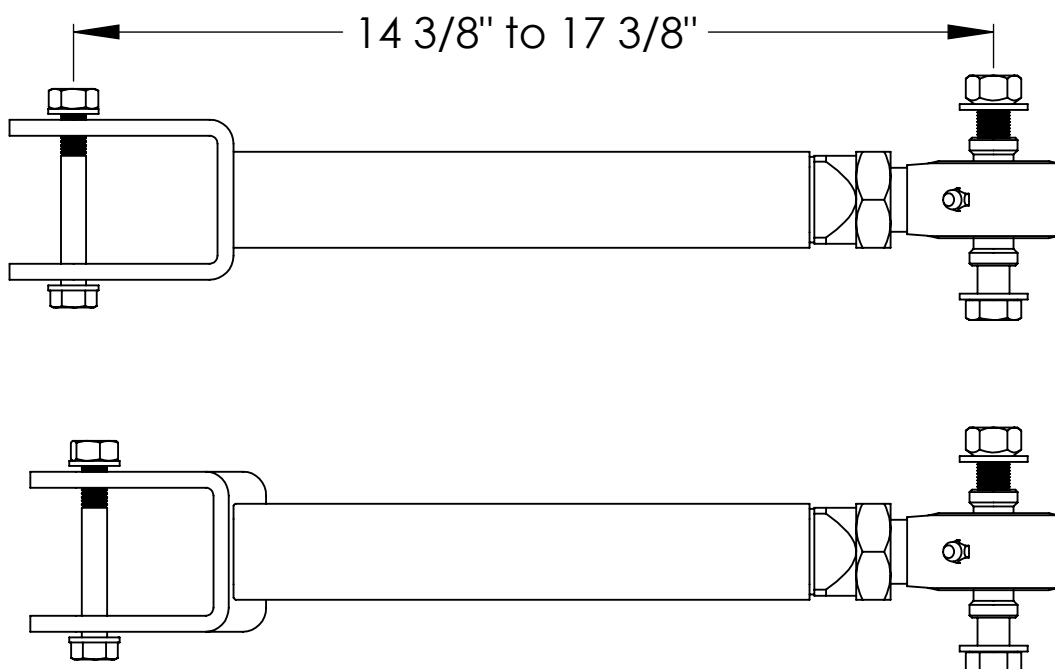

**CLAYTON OFF ROAD**  
**COR-1206010**  
**JEEP GRAND CHEROKEE REAR AXLE TRUSS (1999-2004 WJ)**

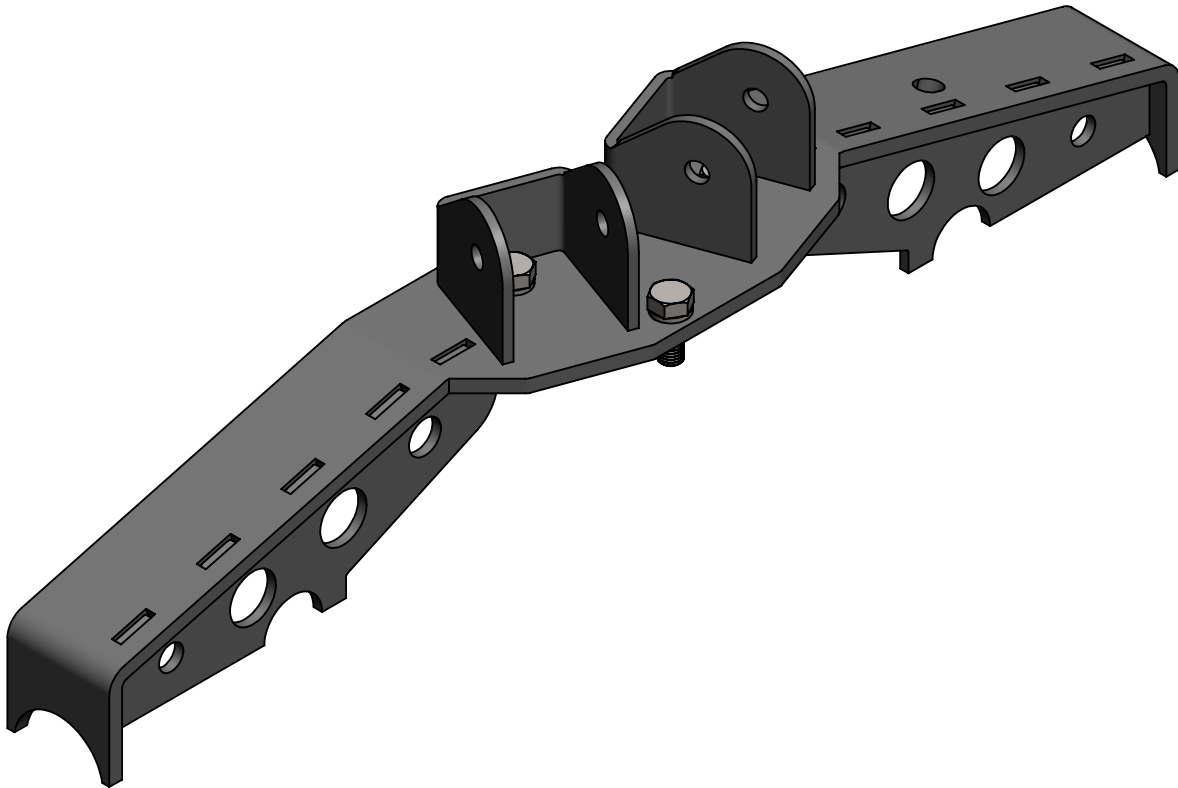

NOTES: This product may require general welding, fabrication and automotive mechanic skills. Welding should only be done by a competent welder. Clayton Off Road implies no guarantees or warranties and is not liable for improper installation. Some grinding and fitment may be required when installing this product. Every vehicle varies slightly and some fabrication may be required.

For more information please visit our website.

Refer to picture below.

Step 1: Remove axle from vehicle.

Step 2: Remove old upper control arm mount.

Step 3: Move brake lines out of the way.

Step 4: Clean axle tubes for welding.

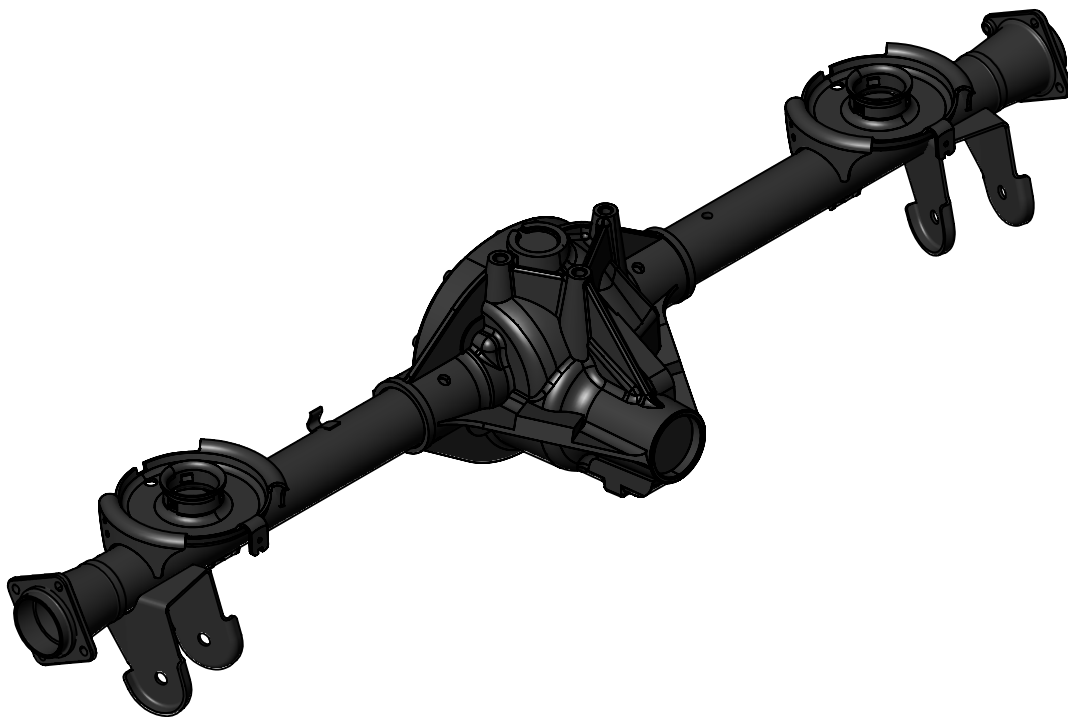

Refer to picture below and 2 drawing views.

Step 5: Slide truss gussets into place.

Step 6: Bolt truss on to axle.

Step 7: Clamp truss ends tight against axle tube.

Step 8: Tack weld four corners of truss.

Step 9: Make sure bottom of gusset is in contact with axle tube.

Step 10: Weld bottom edge of gusset as indicated.

Step 11: Weld in keyways as indicated.

Step 12: Weld truss ends to axle tube on the inside.

Step 13: Remove bolts from truss.

Step 14: Align upper mounts with marks.

Step 15: Weld as indicated.

Step 16: Re-install bolts.

Step 17: Paint axle.

Step 18: Install axle in vehicle.

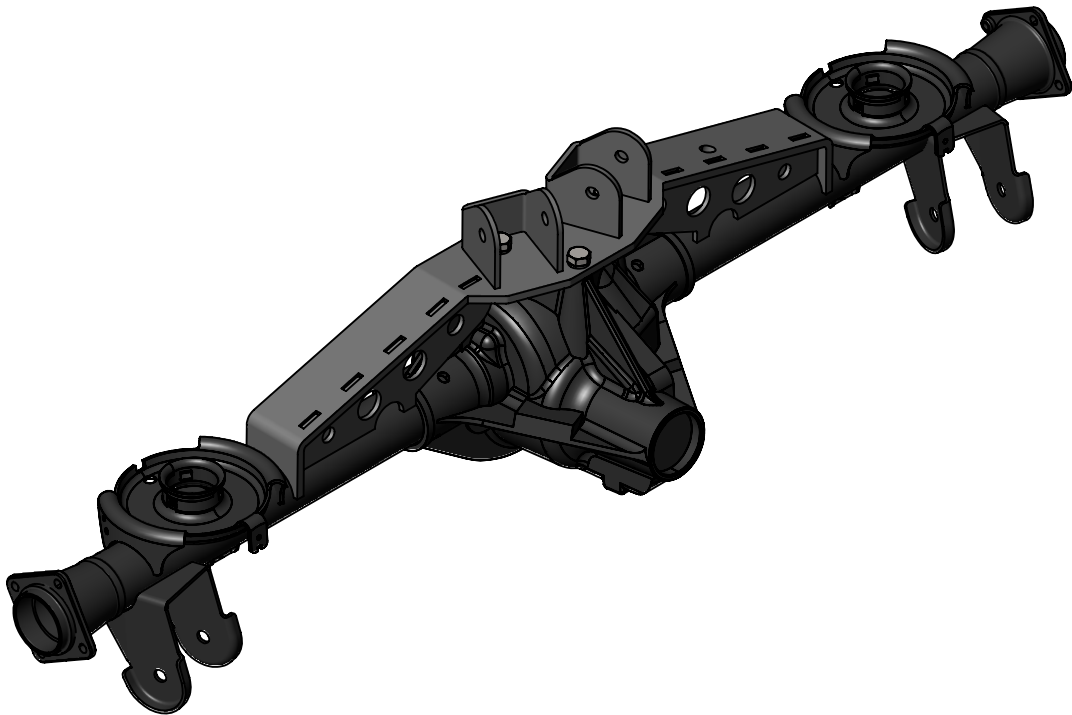



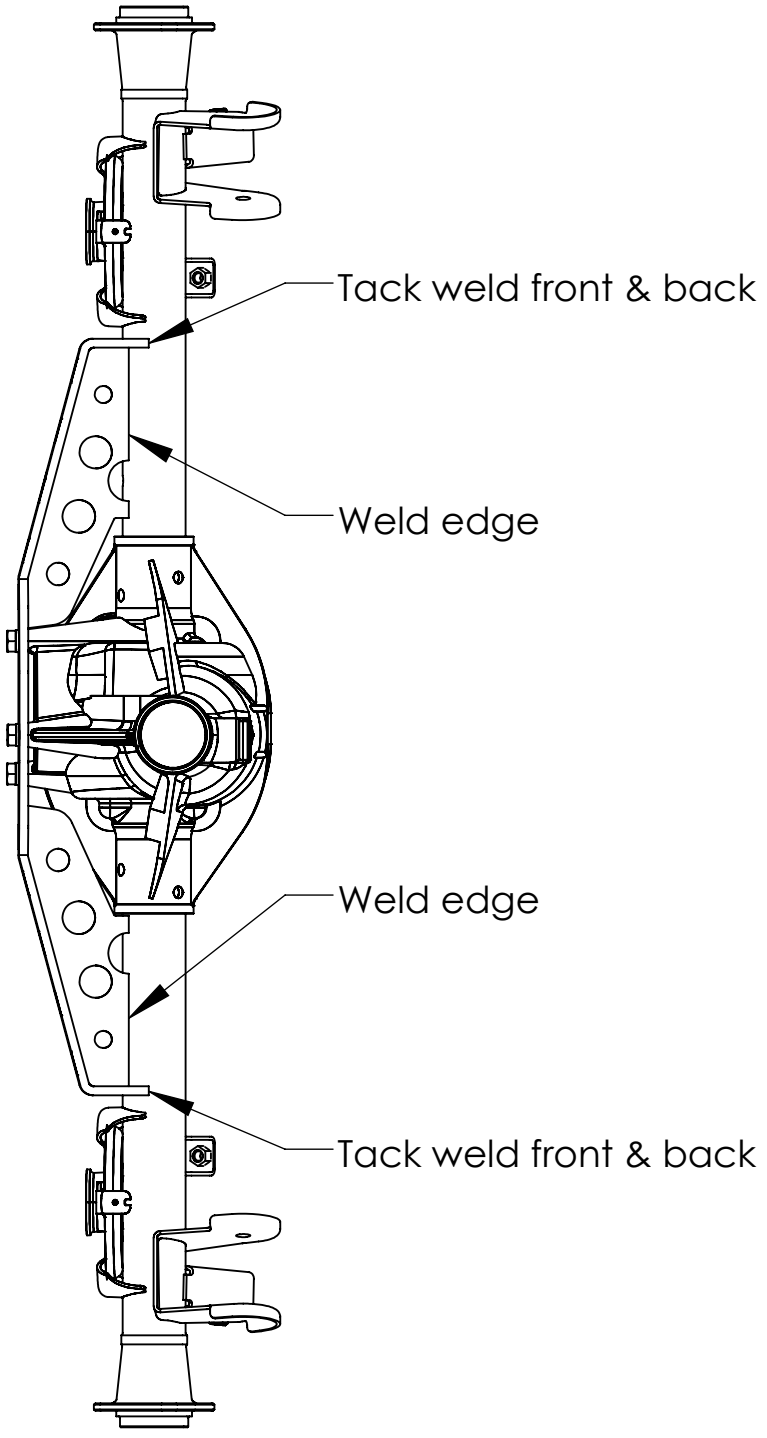

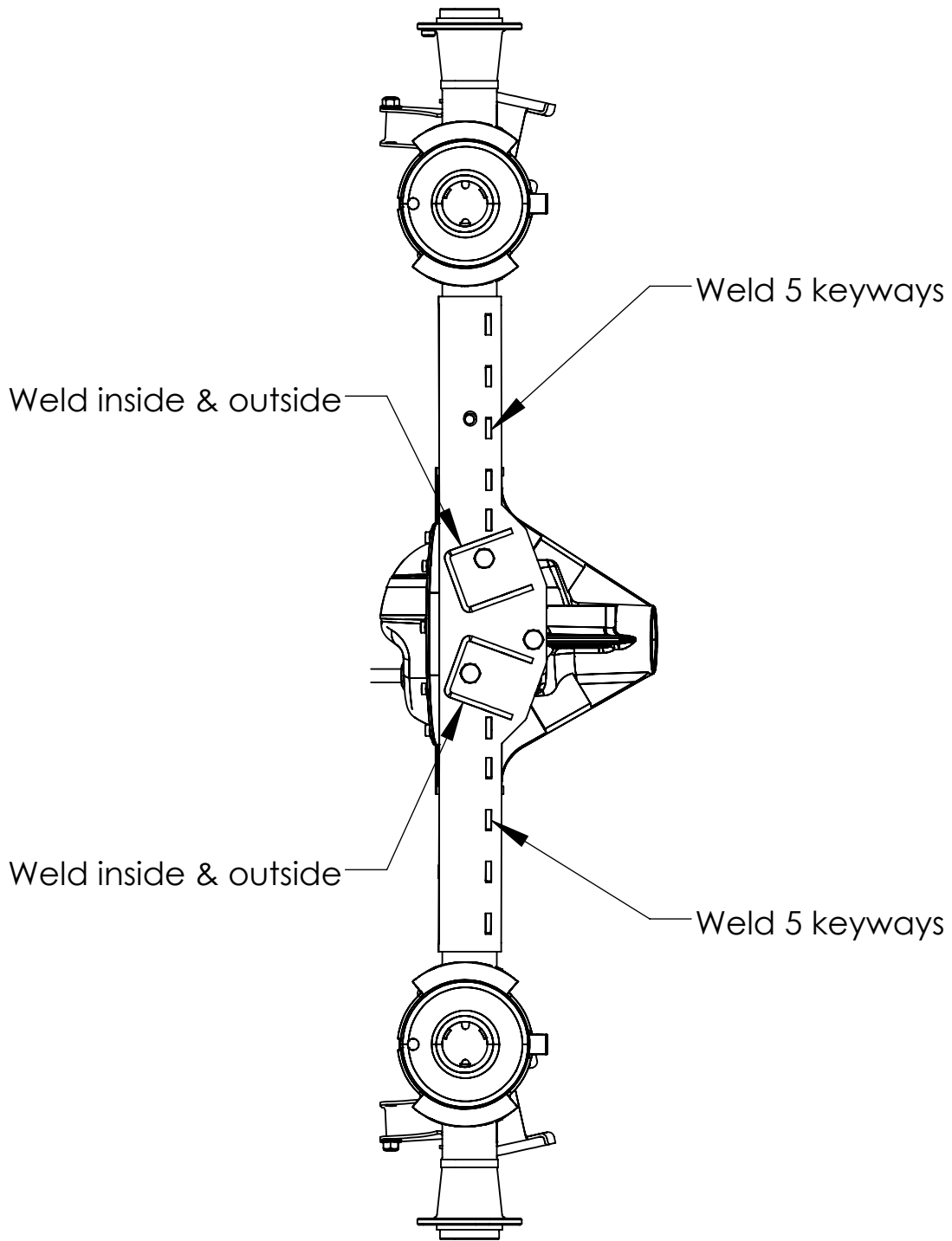

**CLAYTON OFF ROAD  
COR-1206100  
JEEP GRAND CHEROKEE REAR 4-LINK BRACKET (1999-2004 WJ)**

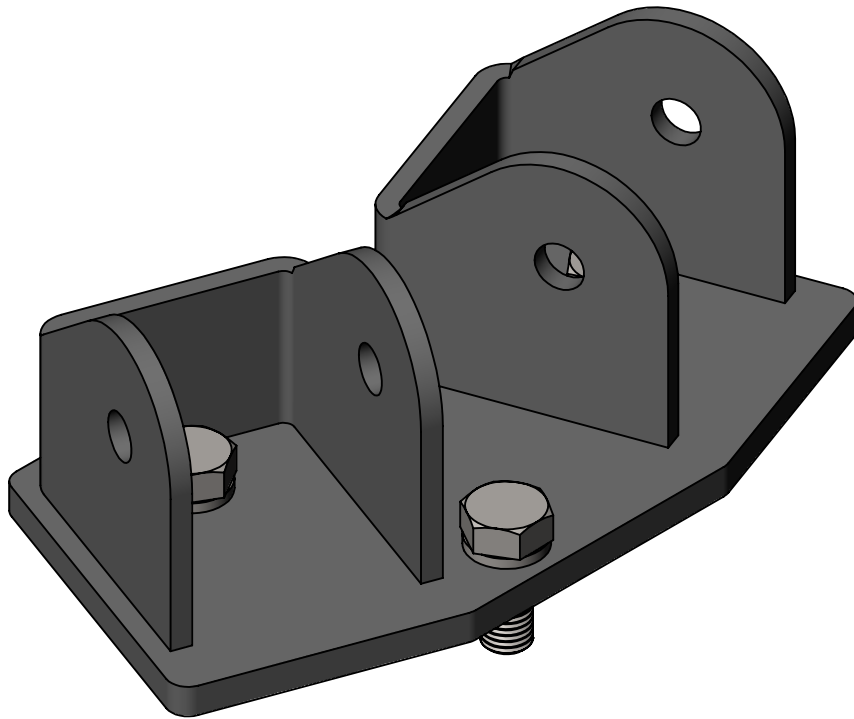

NOTES: This product may require general welding, fabrication and automotive mechanic skills. Welding should only be done by a competent welder. Clayton Off Road implies no guarantees or warranties and is not liable for improper installation. Some grinding and fitment may be required when installing this product. Every vehicle varies slightly and some fabrication may be required. For more information please visit our website.

Refer to picture below and drawing view.

Step 1: Remove upper rear control arm.

Step 2: Remove upper rear arm ball joint.

Step 3: Install rear 4 link bracket using new hardware.

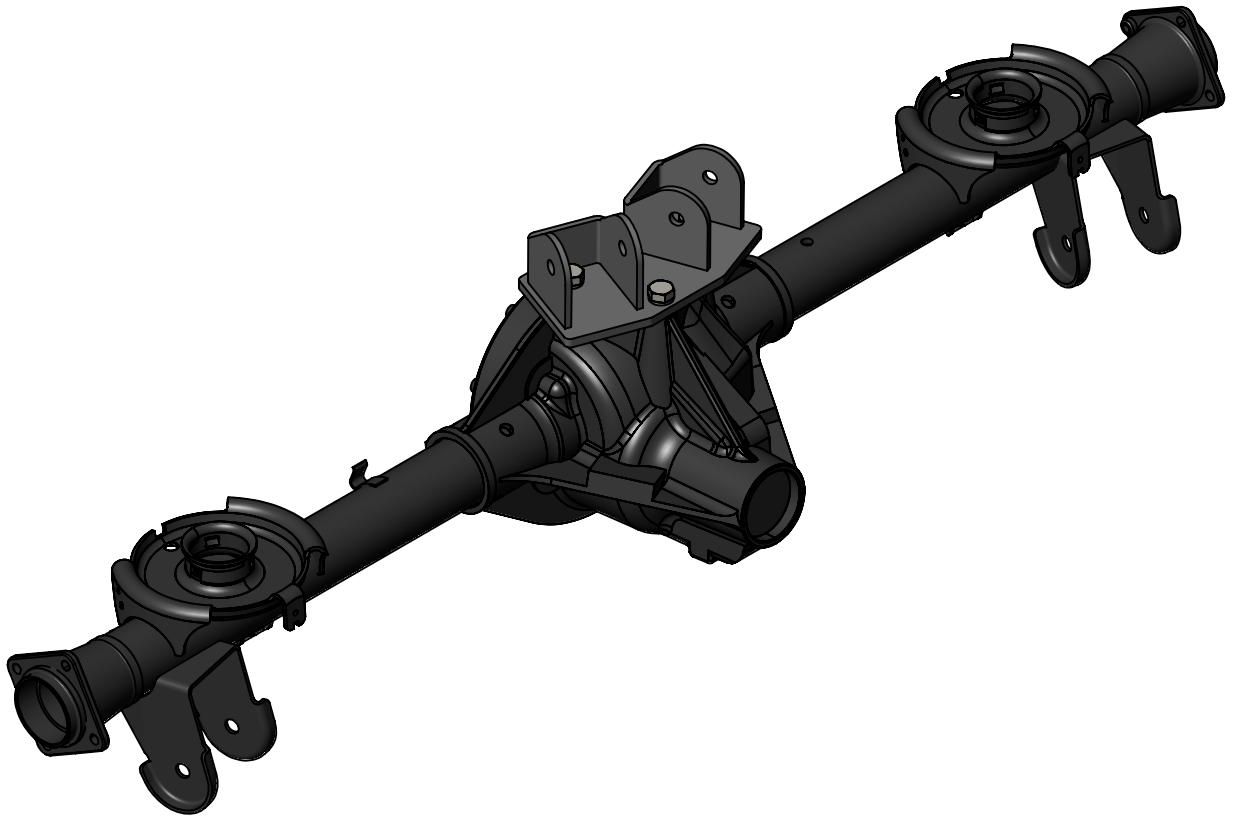

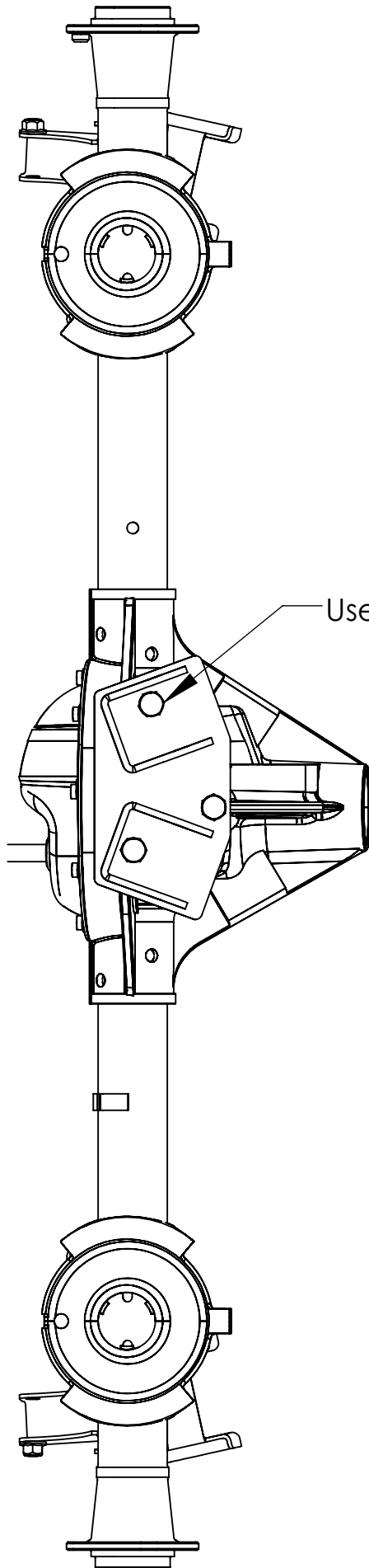

Use new hardware supplied

**CLAYTON OFF ROAD  
COR-1906101  
JEEP GRAND CHEROKEE LONG REAR LOWER CONTROL ARMS (1999-2004 WJ)**



NOTES: This product may require general welding, fabrication and automotive mechanic skills. Welding should only be done by a competent welder. Clayton Off Road implies no guarantees or warranties and is not liable for improper installation. Some grinding and fitment may be required when installing this product. Every vehicle varies slightly and some fabrication may be required.

For more information please visit our website.

Refer to drawing view below and individual product part number instructions.

Step 1: Set one arm as close to recommended length as possible with grease fitting down.

Step 2: Set second arm to same length with grease fitting down. (Use two 9/16" bolts in each end of both arms.)

Step 3: Install part number COR-1206104 control arm spacer kit.

Step 4: Bolt control arm into cross member.

Step 5: Repeat steps 3 and 8 on other side.

Step 6: Tighten bolts after vehicle is sitting at ride height.

Step 7: Tighten jam nuts. (We recommend a 46 mm or 1 13/16" combination wrench for this. We also recommend cutting the box end off the wrench and getting a three foot pieces pipe to put over the end of the wrench for leverage. Inserting a large screw driver between the joint body and the mount will hold the housing joint straight.)

Step 8: The joints are per greased so initial greasing is not required. (We do recommend greasing the joints every time you change your oils or grease other components on your vehicle. Use a hand grease gun not a pneumatic grease gun.

Step 13: Remove grease fittings and install set screws.

**Recommended control arm length for 4.5" to 6.0" of lift is 31.5".  
Some adjustment of this measurement maybe performed for special applications as long as the length stays within the minimum and maximum lengths shown below.**

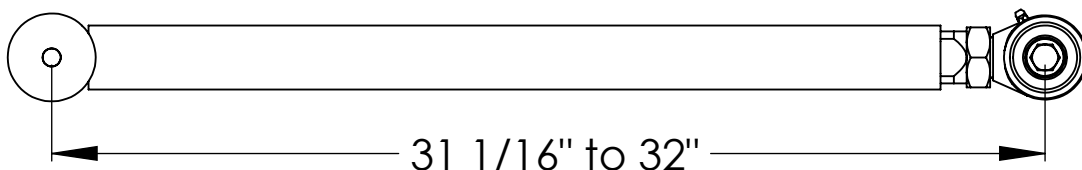

**CLAYTON OFF ROAD  
COR-1900102  
JEEP LONG REAR UPPER CONTROL ARMS (TJ/LJ/ZJ/WJ 1993-2006)**



NOTES: This product may require general welding, fabrication and automotive mechanic skills. Welding should only be done by a competent welder. Clayton Off Road implies no guarantees or warranties and is not liable for improper installation. Some grinding and fitment may be required when installing this product. Every vehicle varies slightly and some fabrication may be required.

For more information please visit our website.



Refer to drawing view below.

Step 1: Set both arms as close to recommended length as possible with grease fittings lined up.

Step 2: Set desired pinion angle. (1 to 2 degrees down is recommended for CV style drive shafts, a bottle jack works well for this.)

Step 3: Center chassis over axle. (Ratchet straps work well for this.)

Step 4: Install one arm at frame end with grease fittings up.

Step 5: Adjust the length of the arms so that you can easily get the bolt in at the axle end with the grease fitting up.

Step 6: The center ball of the Johnny Joint may need to be aligned for the bolt to get the bolt to go in easily.

Step 7: Repeat steps 4 and 6 on other side.

Step 8: Tighten bolts after vehicle is sitting at ride height.

Step 9: Tighten jam nuts. (We recommend a 1 7/16" combination wrench for this. We also recommend cutting the box end off the wrench and getting a three foot pieces pipe to put over the end of the wrench for leverage. Inserting a large screw driver between the joint body and the mount will hold the housing joint straight.)

Step 10: The joints are pre greased so initial greasing is not required. (We do recommend greasing the joints every time you change your oils or grease other components on your vehicle. Use a hand grease gun not a pneumatic grease gun.)

**Recommended control arm length for 4.5" to 6.0" of lift is 34".**

**Some adjustment of this measurement maybe performed for special applications as long as the length stays within the minimum and maximum lengths shown below.**

