

PLEASE READ BEFORE INSTALL!

Note: Jeep Gladiator (JT) and Jeep Wrangler (JL) Front Sway Bar End Links are intended to come with **three studded Rod ends** and **one single Heim Joint end** (as pictured below). The **Heim Joint is to be used on the passenger side end link at the bottom** for proper clearance with the factory double shear bracket, eliminating the need for cutting up your vehicle. Please see back for measurements.

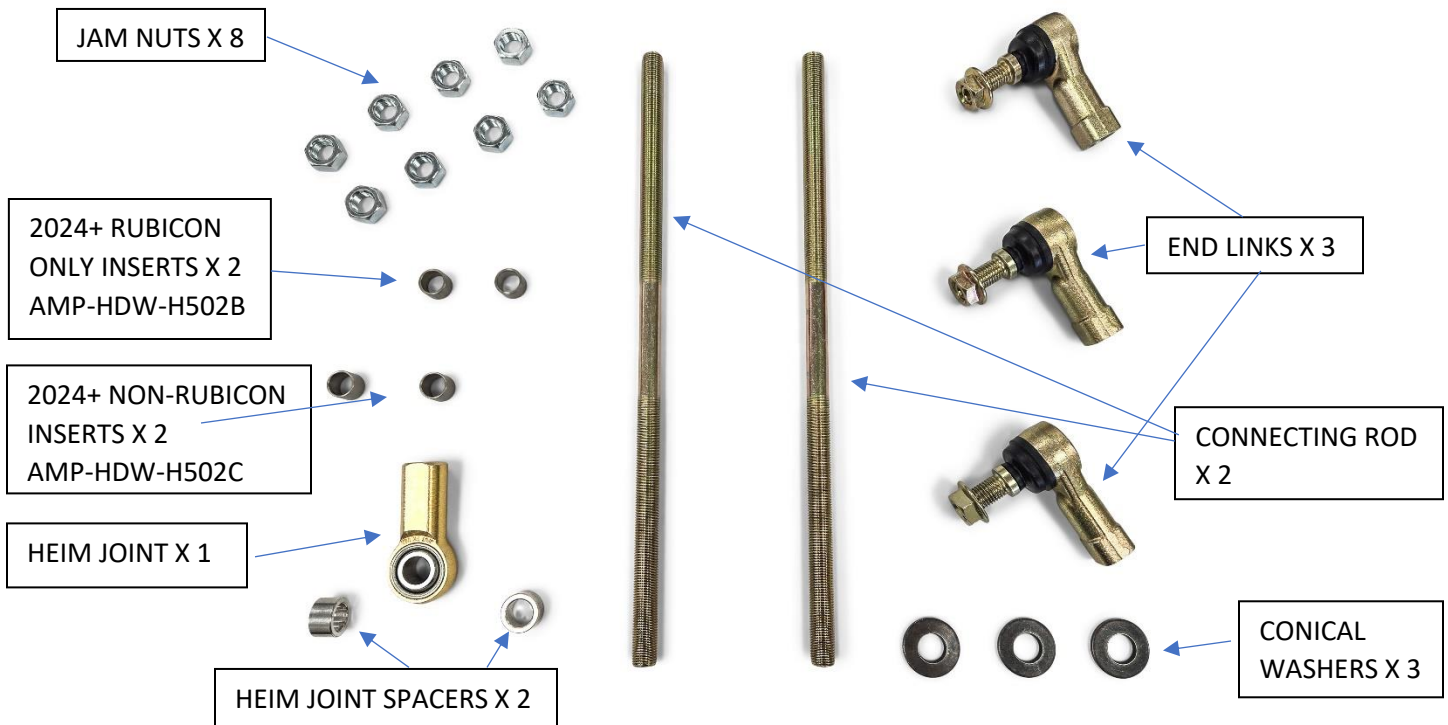

PLEASE USE CONICAL WASHERS ON ALL MODELS AND YEARS!

Conical Washers provide an even greater surface area through beveled sides, distributing the force of the tightening nut while reducing vibrations and preventing the nut from loosening.

2024+ JL & JT MODEL UPDATE

Note: From our current and available research, Jeep is now using 2 different sway bar designs on 2024+ JL and JT models, a solid version on Rubicon models and a hollow version on all others, so three conical washers and two bushing inserts are now included as a fix for both versions.

Non-Rubicon models with the hollow sway bar will need to utilize both the conical washers and bushing inserts **PN – AMP-HDW-H502B**, which are inserted directly into the factory sway as shown on page 2.

Rubicon models with the solid version of the sway bar will need to utilize both the conical washers and bushing inserts **PN – AMP-HDW-H502C**, which are inserted directly into the factory sway as shown on page 2.

The bushing inserts will NOT be necessary on 2018-2023 models.

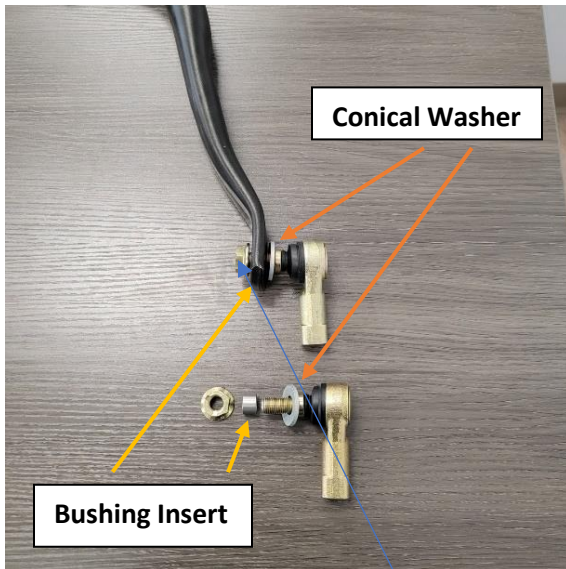

End Link | Sway bar

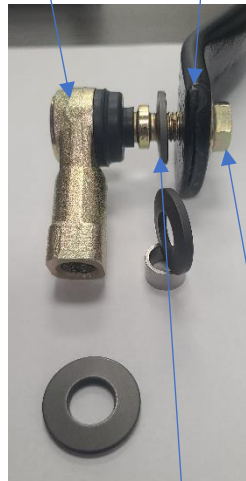

**Conical washer
this side only!**

Conical Washers must be installed on the end link side, with the bow facing away from sway bar.

You want the end link to press against the bulge and compress it during installation which will help prevent loosening and provide a larger surface area.

Torque spec on end link nut = 90-100 ft/lbs

Lift Height	Stock	1.5" Lift		2.5" Lift		3.5" Lift		4.5" Lift	
		Center Length	Cut Each End	Center Length	Cut Each End	Center Length	Cut Each End	Center Length	Cut Each End
JK Front Sway Bar Link	5.250	8-1/4"	3-7/16"	9-1/4"	2-15/16"	10-1/4"	2-7/16"	11-1/4"	1-15/16"
JK Rear Sway Bar Link	8.750	10-3/4"	2-3/16"	11-3/4"	1-5/8"	12-3/4"	1-3/16"	13-3/4"	5/8"
JL Front Sway Bar Link	5.0625	8-1/4"	3-7/16"	9-1/4"	2-15/16"	10-1/4"	2-7/16"		
JL Rear Sway Bar Link	8.75	10-3/4"	2-3/16"	11-3/4"	1-5/8"	12-3/4"	1-3/16"		
JT Front Sway Bar Link	5.063	8-1/4"	3-7/16"	9-1/4"	2-15/16"	10-1/4"	2-7/16"		
JT Rear Sway Bar Link	10.625	12-5/8"	1-1/4"	13-5/8"	3/4"	14-5/8"	1/4"		

